



United States Department of Agriculture

# Urban Tree Monitoring: A Resource Guide



Forest  
Service

Pacific Southwest  
Research Station

General Technical  
Report PSW-266

August 2020

## Abstract

The guidelines proposed in *Urban Tree Monitoring: A Resource Guide* (hereafter referred to as the Resource Guide) were developed and refined over many years to address the need for standardized urban tree monitoring protocols. The Resource Guide provides in-depth guidance for urban forest managers and researchers who want to design and implement a tree monitoring project. This Resource Guide is a companion to *Urban Tree Monitoring: A Field Guide*; however, the Resource Guide can also be used on its own. The Resource Guide is divided into three parts. In Part I, we discuss (1) the varied goals of monitoring projects and how to match data collection to those goals, (2) the development of these urban tree monitoring standards, (3) types of monitoring projects, and (4) connections to other protocols for urban tree data collection. We offer guidance on methods for recording tree location, developing tree record identifiers, organizing spreadsheets and databases, choosing data collection systems, fostering research-practice partnerships, training crews, and managing fieldwork. In Part II, we present five monitoring data sets: Minimum Data Set, Tree Data Set, Site Data Set, Young Tree Management Data Set, and Community Data Set. We list study goals that could be addressed with each data set and descriptions of relevant variables. We also provide guidance regarding which variables are best suited for beginner and advanced crews. Lastly, in Part III we include appendices with additional resources for designing and implementing tree monitoring projects.

## Cover photo

Indian laurel fig trees (*Ficus microcarpa*) line streets in Santa Monica, CA. Photo by Natalie S. van Doorn, USDA Forest Service.

The use of trade or firm names in this publication is for reader information and does not imply endorsement by the U.S. Department of Agriculture of any product or service.

Manuscript received for publication November 2019

---

Published by:  
USDA FOREST SERVICE  
800 BUCHANAN STREET  
ALBANY, CA 94710

For additional copies, email:  
sm.fs.psw-comms@usda.gov

August 2020

---

Visit our homepage at: <https://www.fs.fed.us/psw/>

## Authors

NATALIE S. van DOORN is a research urban ecologist, U.S. Department of Agriculture, Forest Service, Pacific Southwest Research Station, 800 Buchanan Street, Albany, CA 94710.

LARA A. ROMAN is a research ecologist, U.S. Department of Agriculture, Forest Service, Northern Research Station, Philadelphia Field Station, 100 N 20th Street Suite 205, Philadelphia, PA 19103.

E. GREGORY McPHERSON is a research forester (retired) and PAULA J. PEPER is an urban ecologist (retired), U.S. Department of Agriculture, Forest Service, Pacific Southwest Research Station, 1731 Research Park Drive, Davis, CA 95616.

BRYANT C. SCHARENBRUCH is an assistant professor of soil science, University of Wisconsin-Stevens Point, College of Natural Resources, 800 Reserve Street, Stevens Point, WI 54481, and research fellow at The Morton Arboretum, 4100 Illinois Route 53, Lisle, IL 60532.

JASON G. HENNING is a research forester, Davey Institute, a division of the Davey Tree Expert Company, and a contractor with U.S. Department of Agriculture, Forest Service, Philadelphia Field Station, 100 N 20th Street, Suite 205, Philadelphia, PA 19103.

JOHAN P.A. ÖSTBERG is a researcher, Swedish University of Agricultural Sciences in Alnarp, Department of Landscape Architecture, Planning and Management, Box 66, 23053, Alnarp, Sweden.

LEE S. MUELLER is a forestry specialist, the Davey Resource Group, Inc., 1500 North Mantua, Kent, OH 44240 and formerly the program director, Urban Forest Project for Friends of Grand Rapids Parks in Grand Rapids, Michigan.

ANDREW K. KOESER is an assistant professor, University of Florida Gulf Coast Research and Education Center, 14625 County Road 672, Wimauma, FL 33598;

JOHN R. MILLS is a research forester (retired), U.S. Department of Agriculture, Forest Service, Pacific Northwest Research Station, 620 SW Main, Suite 400, Portland, OR 97205.

RICHARD A. HALLETT is a research ecologist, U.S. Department of Agriculture, Forest Service, Northern Research Station, New York City Urban Field Station, 431 Walter Reed Road, Bayside, NY 11359.

JOHN E. SANDERS is a research specialist and JOHN J. BATTLES is a professor, University of California, Department of Environmental Science, Policy and Management, Berkeley, 130 Mulford Hall, Berkeley, CA 94720.

DEBORAH J. BOYER is a project manager, Azavea, 990 Spring Garden Street, Fifth Floor, Philadelphia, PA 19123.

JASON P. FRISTENSKY is a project manager, the Berger Partnership P.S., 1721 8th Avenue N, Seattle, WA 98109 and formerly a research assistant, U.S. Department of Agriculture, Forest Service, Philadelphia Field Station, 100 N 20th Street Suite 205, Philadelphia, PA 19103.

SARAH K. MINCEY is an associate director, Indiana University-Bloomington, Integrated Program in the Environment, Multidisciplinary Science Building II 134, 702 N Walnut Grove Avenue, Bloomington, IN 47405.

JESS VOGT is an assistant professor, DePaul University, Environmental Science and Studies, 1 E Jackson Boulevard, Chicago, IL 60604.

# Contents

<b>Part I: General Strategies for Urban Tree Monitoring</b> . . . . .	1
1. Introduction . . . . .	2
1.1. Why Monitor Urban Trees? . . . . .	2
1.2. Monitoring Project Types . . . . .	7
1.3. Connecting Monitoring Goals to Field Methods. . . . .	8
1.4. Background . . . . .	10
2. Getting Started . . . . .	19
2.1. Planning Ahead for Data Collection, Management, and Analysis. . . . .	19
2.2. What Is a Tree? . . . . .	28
2.3. Choosing the Appropriate Location Method . . . . .	30
2.4. Site Type and Land Use . . . . .	41
2.5. Longitudinal Database Considerations . . . . .	44
3. Managing Fieldwork . . . . .	55
3.1. Tips for Training Field Crews . . . . .	55
3.2. Tips for Managing and Supporting Field Crews . . . . .	59
3.3. Field Equipment Suggestions . . . . .	64
4. Conclusion . . . . .	67
<b>Part II: Data Sets for Urban Tree Monitoring</b> . . . . .	69
5. Data Sets Framework. . . . .	70
6. Minimum Data Set . . . . .	72
6.1. Basic Record Information . . . . .	73
6.2. Location and Site. . . . .	74
6.3. Tree Data. . . . .	74
6.4. Background on Mortality Status. . . . .	75
6.5. Background on Crown Vigor . . . . .	77
6.6. Background on Trunk Diameter. . . . .	78
7. Tree Data Set . . . . .	81
7.1. Tree Size Measurements. . . . .	82
7.2. Tree Condition and Maintenance . . . . .	83
7.3. Images. . . . .	86
7.4. Background on Fine Twig Dieback . . . . .	86

8. Site Data Set . . . . .	88
8.1. Roads . . . . .	88
8.2. Buildings . . . . .	90
8.3. Hardscapes . . . . .	90
8.4. Overhead Conflicts . . . . .	90
8.5. Soil. . . . .	91
9. Young Tree Management Data Set . . . . .	92
9.1. Program Information . . . . .	93
9.2. Tree Steward Information . . . . .	93
9.3. Stewardship Actions . . . . .	94
10. Community Data Set . . . . .	95
10.1. High-Priority National Data . . . . .	96
10.2. Local Data . . . . .	96
10.3. Community Surveys and Interviews . . . . .	97
11. Acknowledgments. . . . .	98
<b>Part III: Supporting Documentation . . . . .</b>	<b>99</b>
Literature Cited. . . . .	100
Appendix 1: Site Type and Land Use Examples . . . . .	116
Appendix 2: Species Identification Resources . . . . .	119
Web Sites and Apps . . . . .	119
Books . . . . .	120
Appendix 3: Other Protocols. . . . .	122
Appendix 4: Field Crew Training Agendas and Activities . . . . .	124
Agenda No. 1: Full-Day (7 Hours) Field Crew Training Agenda for Interns or Citizen Scientists . . . . .	124
Agenda No. 2: Short (2.5 hours) Training Agenda for Interns or Citizen Scientists. . . . .	125
Glossary . . . . .	129



## Foreword

We wrote *Urban Tree Monitoring: A Resource Guide* (hereafter Resource Guide) to assist managers, researchers, and students of urban forestry and urban ecology in field-based tree monitoring projects. We have each been involved with numerous tree monitoring projects conducted in settings ranging from urban to rural, for research and management applications, with field crews including volunteers, students, interns, and professionals. The Resource Guide encompasses best practices we have learned through years of fieldwork and associated data management. We briefly describe our relevant experiences below, which have informed the many suggestions found throughout the Resource Guide.

Natalie S. van Doorn supervised field crews and managed data collection for permanent, rural forest plots for the National Science Foundation's Long-Term Ecological Research program at Hubbard Brook Experimental Forest, New Hampshire, for 12 years and has been working with long-term urban tree data for 5 years. John J. Battles, John E. Sanders, and Richard A. Hallett have also worked with permanent, rural forest plots in experimental forests at Hubbard Brook and elsewhere, for 34, 10, and 21 years, respectively. Lara A. Roman has collected data and supervised field crews for yard and street tree monitoring in northern California and Philadelphia, PA, for 13 years, and has trained citizen scientists. E. Gregory McPherson and Paula J. Peper have been involved with collecting, managing, and analyzing street tree inventories across the United States for more than 20 years. Bryant C. Scharenbroch has worked on urban soils and tree inventories in Chicago, IL, and elsewhere for 9 years. Jason G. Henning has taught forest measurements and collected rural forestry data for 12 years and worked with urban forestry data related to i-Tree from across the United States for 6 years. Johan P.A. Östberg has been doing urban forestry field inventories for 11 years and developed urban tree inventory standards for Sweden. Lee S. Mueller has recruited, managed, and supported volunteers for tree inventory and assessment projects in Detroit and Grand Rapids, MI, for 7 years. Deborah J. Boyer has worked with urban forest inventory software for municipal, nonprofit, and state organizations for 7 years. Andrew K. Koeser has supervised tree inventories and post-hurricane assessments across Florida for 7 years, using the data collected to assess past management efforts and guide best practices. Jess Vogt and Sarah K. Mincey have supervised street tree data collecting in Indianapolis, Indiana, and other cities for 8 years, and have developed protocols for monitoring recently planted trees, and Jess Vogt has also taught inventory methods for 4 years. Jason P. Fristensky worked as a field crew member and database manager for urban tree inventories for 1 year and has been a landscape architect for 6 years.

We sincerely hope that readers find the Resource Guide and the companion *Urban Tree Monitoring: A Field Guide* useful when implementing urban tree monitoring projects, as these documents contain the kinds of information that we all would have benefited from when we began long-term field studies of urban trees. Our experiences and examples in this Resource Guide are mostly from the United States, but the strategies and suggestions we offer are broadly applicable to urban tree monitoring worldwide.

---

## **Part I: General Strategies for Urban Tree Monitoring**

---

# 1. Introduction

*Urban Tree Monitoring: A Resource Guide* (hereafter Resource Guide) is a companion to *Urban Tree Monitoring: A Field Guide* (hereafter Field Guide) (Roman et al. 2020). Whereas the Field Guide provides detailed protocols for a core set of variables and can be used by professionals, researchers, interns, and volunteers in the field, the Resource Guide provides in-depth guidance for urban forest managers and researchers who want to design and implement a **monitoring** project. Throughout the Resource Guide, we discuss various goals of monitoring projects and how to match data collection methods to those goals, the background of the development of these urban tree monitoring guidelines, types of monitoring projects, connections to other protocols for urban tree data collection, tips for training crews and managing fieldwork, guidance on selecting tree location methods and tree record identifiers, and detailed explanations of monitoring data sets.

Notably, while the term **urban forest** is generally used in the United States to refer to all trees in cities and urbanized areas, both public and private, including street, yard, and park trees (Konijnendijk et al. 2006, Nowak et al. 2010, Piana and Troxel 2014), our Field Guide and Resource Guide focus on trees along streets and in lawns (including residential lawns, park lawns, as well as other landscaped spaces). We do not cover trees in wooded or natural areas of urban parks because these would require a different monitoring approach. For further reading about field methods for inventories and monitoring in rural forest systems, see Avery and Burkhart (2001), Brassel and Lischke (2001), Husch et al. (2002), Van Laar and Akca (2007), and West (2009). It is important to recognize that trees in different parts of the urban ecosystem have different environmental conditions and population dynamics, which can require different approaches to inventory and monitoring methods.

Throughout this document, terms in **bold** are defined in the Glossary (page 127).

Monitoring is a key element of sustainable urban forest management. As suggested by Clark et al. (1997), assessing urban forest resources for sustainability entails “collect[ing] information about the urban forest on a routine basis.” This is more than a static “snapshot” inventory. A single, static inventory can be used to understand structure, function, and ecosystem services at a given point in time—such as tree size class distribution, species composition, and associated environmental benefits—but an inventory can quickly become outdated in the dynamic urban landscape. Indeed,

---

*Urban Tree Monitoring: A Resource Guide* focuses on trees along streets and in lawns.

---

## 1.1. Why Monitor Urban Trees?

---

Monitoring studies describe change over time.

---

recognizing the value of long-term field data, many municipal arborists, urban greening nonprofits, and states are already engaged in ongoing monitoring (Roman et al. 2013). Additionally, many research articles about monitoring urban tree **mortality** (and its flip side, survival), growth, and health have been published in the past few years, demonstrating increasing interest in the topic from scholars (e.g., Breger et al. 2019; Hallett et al. 2018; Hilbert et al. 2019; Ko et al. 2015a, 2015b; Koeser et al. 2014; Lima et al. 2013; Martin et al. 2016; Roman et al. 2014a, 2014b; Roman et al. 2015; Vogt et al. 2015a; van Doorn and McPherson 2018; Widney et al. 2016). While a single inventory can describe structure and spatial patterns in an urban forest, only monitoring data can describe change over time.

---

Longitudinal data consist of repeated observations of the same individual trees.

---

In this report, we focus on **long-term field monitoring**, although there are certainly other kinds of monitoring relevant to urban forests (Leff 2016), including using aerial imagery, LiDAR, and remote sensing to detect changes in tree cover. One could also assess changes over time in the human communities and institutions that steward trees. But, in this report, we specifically focus on field monitoring of urban trees to produce **longitudinal data**: repeated observations of the same individual trees. Longitudinal studies are essential for research on **tree demography**—the study of population dynamics—including analysis of change over time in mortality, growth, and health. While such studies are relatively new to urban forestry, longitudinal monitoring studies are more widespread in rural forests (Roman et al. 2016). Studies of tree demography in rural forests can include analysis of tree mortality, growth, **ingrowth**, and regeneration within plots or stands, and likewise, tree demography studies of yard or street trees can include analysis of tree mortality (including removal), growth, and planting (with some natural regeneration possible depending on site conditions). The urban tree monitoring standards presented in the Field Guide, and tips offered in the Resource Guide, support structured longitudinal studies of urban trees. Our urban tree monitoring standards are focused on trees whose population cycles are anthropogenically controlled (Roman et al. 2016). Although several dozen urban forestry programs in the United States already engage in tree monitoring (Roman et al. 2013), methods differ widely, and it is important to have coordinated efforts to collect monitoring data across many cities (for examples of coordinated monitoring projects across cities, see McPherson et al. 2016, Widney et al. 2016). The variation in methods presents challenges for managers and researchers to compare data across cities and programs. Such inter- and intra-city comparisons using standard data are important to illuminate typical rates of mortality and growth across regions and species and to facilitate studies concerning which factors influence those outcomes.

---

The intended objectives should be decided at the beginning of a monitoring project.

---

Urban tree field monitoring can serve several management and research goals, whether for inter- or intra-city studies. However, no single project can achieve all these goals, making it important to decide the intended objectives at the beginning of a monitoring project. Some possible goals (listed in no particular order) are offered below.

---

Tree performance outcomes may include growth, survival, health, and associated ecosystem services.

---

- **Evaluating planting program performance.** Tracking trees planted through a particular program can yield information about tree performance outcomes—such as growth, survival, health, and associated ecosystem services. For many municipalities and nonprofits that conduct tree monitoring, tree performance outcomes serve as metrics of program success. For example, New York City Parks & Recreation (New York, NY) collected data on street tree survival in relation to social and ecological factors (Lu et al. 2010). Researchers collaborating with the Sacramento Tree Foundation and Sacramento Municipal Utility District in Sacramento, CA, monitored the survival and growth of residential shade trees to determine how well the initial energy-saving projections matched observed performance (Ko et al. 2015a, 2015b; Roman et al. 2014a). In San Francisco, CA, researchers collaborated with the nonprofit organization Friends of the Urban Forest to monitor growth and vigor of commonly planted ornamental trees (Martin et al. 2016).
- **Understanding the ecological and social factors that predict tree mortality, growth, and health.** Studies that track factors that might be associated with tree mortality, growth, and health can improve our scientific and practical understanding of how urban tree systems change through time. Studies that incorporate long-term monitoring can also suggest potential areas for program enhancement and identify trees at higher risk for decline. For example, the aforementioned studies of residential shade trees in Sacramento showed that tree mortality was linked with homeowner instability (i.e., foreclosures, home sales, and renter-occupied properties), and that homeowner instability was connected to poor maintenance practices by residents (Ko et al. 2015a, Roman et al. 2014a). This suggested the need to support residential tree maintenance over time, even with new owners and tenants. Street tree studies have also shown the importance of maintenance and especially watering regimes on tree survival (Breger et al. 2019; Koeser et al. 2014; Mincey and Vogt 2014; Vogt et al. 2015a). Additionally, some urban tree monitoring studies have shown how mortality and health outcomes differ by species or groups of species, in relation to ecological factors such as drought tolerance, city microclimates, and coastal flooding (Hallett et al. 2018, Ko et al. 2015a, Koeser et al. 2014, Martin et al. 2016, Roman et al. 2014a, ). In the same vein, qualitative evaluations of street tree planting programs with unusually high or low performance (e.g., very high or very low establishment survival) can suggest elements essential for tree survival (Breger et al. 2019, Roman et al. 2015, Yang and McBride 2003). Studies based on repeated plot inventories can similarly be used to understand factors associated with urban tree mortality, growth, and health. Such plot-based studies have also assessed changes in urban forest structure and ecosystem services over time and the impacts of extreme weather events (e.g., Lawrence et al. 2012, Lima et al. 2013, Nowak et al. 2013b, Staudhammer et al. 2011). Notably, some

of the plot-based studies span many different **land uses** and **site types** in the urban forest, including forested stands in parks, residential trees, and street trees.

- **Engaging local communities.** Community engagement in urban forestry can involve **citizen science** (Roman et al. 2017, 2018a). Citizen science engages the public in ecological research and natural resource management (Dickinson et al. 2010, 2012; Tulloch et al. 2013), typically using volunteers to collect field data (Silvertown 2009). For example, some nonprofits recruit volunteers to track recently planted trees, including Friends of the Urban Forest (San Francisco, CA), Canopy (Palo Alto, CA), and the Pennsylvania Horticultural Society (Philadelphia, PA). When volunteers observe tree maintenance issues, that information can be used to inform residents about tree condition and provide recommendations for improved stewardship. Additionally, volunteers have been engaged in citywide street tree inventories, including Portland, OR, and New York, NY (Crown et al. 2018, Silva et al. 2013, St. John 2011). Many of these citizen science programs operate as event-based field campaigns, with volunteers going out on specific days, sometimes organized as “mapping parties.” This contrasts with **crowdsourcing** approaches to urban tree data collection, in which large numbers of volunteers submit data when and where they wish. While citizen science has been used in these varied urban forestry examples, data quality can be a concern. Recent studies that have assessed volunteer data quality in street tree inventories include Roman et al. (2017, 2018b), Bancks et al. (2018), Hallett and Hallett (2018), and Hamilton et al. (2018). Those studies suggest that project supervisors should connect data quality needs to field crew training and appropriateness of utilizing volunteers. For certain variables and certain uses of the data, volunteer-generated data quality is appropriate (see sections 1.3, 1.4.3, and 2.1.9 for further discussion about data quality and volunteers).
- **Managing pruning cycles and tree risk.** This is especially relevant for street trees, which require frequent inspections to guide pruning and removal of aging and hazardous trees (Harris et al. 2004, Pokorny 2003). Repeated street tree inventories can be integrated with a municipal forester’s regular inspection and pruning cycle. For instance, a municipal arborist could inspect one-fifth of the town’s street trees each year and update the inventory each year with tree mortality and new planting data, such that inspections and inventories are completed in a 5-year cycle. This kind of systematic inventory/inspection cycle ensures that records are up to date for proactive management and allows for analysis of mortality and tree risk (Hauer and Peterson 2016, Roman et al. 2013).
- **Producing empirical data for population projection and ecosystem services models.** Incomplete information about tree mortality is acknowledged as a major source of uncertainty in models that project urban forest populations into the future to estimate ecosystem services

---

To evaluate the appropriateness of using volunteers for urban tree monitoring, consider data quality needs and field crew training.

---

---

Generating more tree mortality, growth, and allometry data is critical to improve the accuracy of population projection and ecosystem service models.

---

(McPherson 2014, McPherson et al. 2008, Morani et al. 2011, Roman et al. 2016). Projected ecosystem services are also sensitive to changes in tree growth (Ko et al. 2015b, Widney et al. 2016), yet there is very little empirical data about **tree growth** in urban environments (Roman et al. 2015). Urban tree **allometry**—the sizing relationships of trees (e.g., equations to estimate height, crown dimensions, and biomass from trunk size)—is another essential component of ecosystem services and population projection models (Blood et al. 2016, McHale et al. 2009, McPherson et al. 2016, Troxel et al. 2013). Generating more tree mortality, growth, and allometry data—across cities, programs, species, and site conditions—is critical to improve model accuracy.

- **Detecting emerging threats from pests and diseases.** Monitoring for tree pests and diseases in the urban environment can provide valuable early warnings about threats to both urban and natural forest systems. Field methods designed for pest detection and tree health monitoring have been developed by the U.S. Forest Service and the Healthy Trees, Healthy Cities initiative of The Nature Conservancy. There is also an **i-Tree** module for recording pest detection data (USDA Forest Service 2017c). These tools are similar to pest detection systems for rural forests (Barger and Moorhead 2007), and such monitoring can be geared toward professionals or citizen scientists.
- **Evaluating outcomes of experimental tree plantings.** Experimental tree plantings can be used to evaluate the performance of new species, new cultivars, or responses to changing climate conditions. For example, field tests of serviceberry (*Amalanchier* spp.), crabapple (*Malus* spp.), and callery pear (*Pyrus calleryana*) indicated varying growth rates, condition, and site suitability for different cultivars (Gerhold 2007a, 2007b, 2008). Other studies have experimentally planted species previously untested in a particular climate zone (McPherson and Albers 2014). One such experiment, the Climate-ready Trees project (McPherson et al. 2018), is planting species thought to be adaptable to the predicted future conditions in California climate zones. To determine success or failure of species or cultivars that are new to a city or region, it is important to track their mortality, growth, and health over a number of years, potentially decades.

### 1.1.1. A brief note about mortality and survival terms

Because mortality is often one of the key outcomes of interest in urban tree monitoring studies, we provide here a brief note about the meaning of mortality and survival terms. We define urban tree mortality as a combination of trees observed dead and those that were removed. Mortality observations can be expressed as the **annual mortality rate**, which is the proportion of trees dying (or removed) in a given year. The **annual survival rate** is the flip side of mortality, the proportion of trees surviving in a given year (annual survival = 1 – annual mortality). When tracking trees from a planting

---

We define urban tree mortality as a combination of trees observed dead and those that were removed.

---

project, **survivorship** is the proportion of trees surviving from planting to a particular time (e.g., survivorship to 10 years post-planting). These terms are all rooted in standard definitions from demography and population biology. Survivability, a term often used among urban forestry professionals, does not have a standard definition. See Roman et al. (2016) for more information about how to calculate annual mortality, annual survival, and survivorship, and other applications of demographic concepts to urban forests.

## 1.2. Monitoring Project Types

There are two basic types of field-based urban tree monitoring projects dealt with in the Field Guide and Resource Guide: (1) planting cohort monitoring of relatively even-aged trees, and (2) multi-age inventory monitoring.

---

Planting cohort monitoring tracks trees planted within the same program or initiative.

---

- **Planting cohort monitoring of relatively even-aged trees** (hereafter referred to as planting cohort monitoring). A **planting cohort** is a group of trees planted around the same time (e.g., same planting season or same calendar year). Cohort monitoring is usually intended to track trees planted within the same program or initiative. With a cohort study, the total number of originally planted trees decreases over time as trees die or are removed. If **replacement trees** are planted, then those new cohorts can also be monitored.

---

Multi-age inventory monitoring tracks trees of all ages within a given geographic area.

---

- **Multi-age inventory monitoring.** Monitoring trees within a given geographic area (e.g., city, neighborhood), regardless of who planted or when, is an inventory remeasurement. Inventories may span multiple age classes as a result of different planting campaigns, disturbance intensities (e.g., past storms), and management regimes. Multi-age inventory monitoring could target specific land uses or site types (e.g., residential yards, street trees, neighborhood parks). With this project type, trees can be both added to (via planting or natural regeneration) and removed from (via death in place or human removal) the inventory. The total number of trees monitored may therefore increase or decrease over time. New trees added to the inventory (via planting or regeneration) can be analyzed as ingrowth. Changes in the total population size can be reflected in the **population growth rate** (not to be confused with tree growth rate). Replacement trees can also be monitored to understand the dynamics of the tree population. Changes in species composition and diversity can also be analyzed for multi-age inventory monitoring projects.

Each of the two monitoring types described above can be further categorized based on what portion of trees within the project or geographic area are monitored. In a census, all trees in the planting project or geographic area are inventoried, whereas in a sample, only a selection of trees is measured. For instance, a repeated street tree inventory that covers all streets in a particular city would be a multi-age inventory monitoring project that constitutes a citywide census. But a repeated street tree inventory that involves only selected blocks would be a sample multi-age inventory monitoring project.

---

Tree remeasurements should be linked to the first record of that tree or tree site in the database.

---



---

The basic organizational unit of the longitudinal database can be the planting site or the tree.

---

### 1.3. Connecting Monitoring Goals to Field Methods

---

Monitoring goals should be linked to data collection strategies.

---

For both planting cohort monitoring and multi-age inventory monitoring, tree mortality, growth and replacement rates, as well as health changes, can be analyzed. However, it is essential that all tree remeasurements are linked to the first record of that tree or planting site in the database; this is the essence of longitudinal database structures to track individuals over time (see section 2.5 about longitudinal database considerations). If it is not possible to link the remeasurement or loss of the same tree across time, it will not be possible to analyze the data for individual tree mortality, growth, or health, and summarize outcomes across all the trees studied. For some projects seeking to summarize **stocking** levels (the extent to which growing space is filled with trees) and planting needs over time, the planting site (not the tree) should be the basic organizational unit of the longitudinal database. When tree planting sites (including potential sites) are the central unit of interest in a monitoring project, then vacant sites are part of the inventory and can have different trees residing through the years, but their geographic location remains constant. Tracking planting sites is particularly relevant to street tree planning and management (van Doorn and McPherson 2018, see also section 2.1.14). See section 2.5.3 for example database structures that involve tracking sites and replacement trees.

Each of the goals listed above has associated data needs, and it is essential to link monitoring goals to data collection strategies. Neglecting to articulate up-front clear monitoring objectives, variables to be collected to meet those objectives, and plans for data analysis can lead to the “data-rich but information-poor” scenario of environmental monitoring (Ward et al. 1986) in which analysts become “snowed by a blizzard of ecological details” (Lindenmayer and Likens 2010a). This can sometimes result from poorly articulated goals, leading to an overload of variables without clear uses for each piece of data collected.

As an example of appropriate links between goals and methods, consider the two types of monitoring projects (section 1.2): planting cohort monitoring and multi-age inventory monitoring. Monitoring trees from a planting cohort is a way to evaluate the performance of a planting program. For example, a neighborhood planting program seeks to understand losses during the **establishment phase** (the first few years after planting [Richards 1979]) and determine potential program alterations for enhanced tree survival and vigor. The program also seeks to understand the impacts of tree care and site conditions on survival. Such monitoring of recently planted trees should include data collection for mortality, vigor, and stewardship (e.g., check whether tree care recommendations are being followed, such as irrigation, mulching, staking, and pruning). The program may also choose to record site characteristics for each tree. If volunteers or interns with little prior experience are collecting the data, only a select few variables for site characteristics and tree maintenance observations are appropriate. Additional tree growth and health outcomes may also be relevant to the project,

depending on the program's objectives and field crew skills or training. Planting cohort monitoring can also be used to evaluate growth and vigor of experimental tree planting of new species or cultivars or of commonly planted species across varying site conditions. Such projects may also evaluate species' tolerance for changing climate conditions or pest resistance. Extending monitoring goals beyond mortality outcomes requires collecting additional tree and site variables (see Tree Data Set, section 7, and Site Data Set, section 8).

Next, consider multi-age inventory monitoring. Just as the U.S. Census tracks changes in the human population, a city tree inventory can be used to describe patterns in the urban forest over time. A repeated census or re-inventory can be used to understand whether new plantings are on pace with losses from death and removal. For example, a municipality seeks to assess the extent to which a major street tree planting campaign is influencing overall population size and size class distribution, considering ongoing tree mortality across the city (in other words, determining whether planting rates are keeping up with losses). The municipality is also concerned with identifying trees that need to be pruned or removed to protect public safety and infrastructure. The municipality should do a repeated inventory of all street trees, both existing and newly planted, potentially visiting a fraction of the trees each year in conjunction with an inspection cycle. Analysis and conclusions about mortality and planting rates would be possible after the second census (e.g., an initial census, and then a second census to remeasure the same trees a few years later). A repeated tree census can also be used for pest and disease detection or to track impacts of extreme weather events on tree growth, health, and mortality. Monitoring goals may drive the need for additional variables (e.g., noting whether a tree is a replacement) or change how a variable is analyzed (e.g., basal sprout counted as a new tree) (see sections 2.1.15, 2.1.16, 2.1.17). Whatever the specific project objectives are, they should connect to and inform the data collection methods and analysis plans.

---

Project objectives should connect to and inform the data collection methods and analysis plans.

---

Different monitoring goals and intended uses of the data also have different data quality needs, with implications for how skilled field crews need to be. For example, evaluations of wood condition, tree risk, and pruning needs should be done by professional arborists, not volunteers, based on evidence of low data quality for such variables in citizen science inventories (Bloniarz and Ryan 1996, Cozad 2005, Roman et al. 2017). There may also be liability concerns for municipal urban forest managers that require them to use certified arborists for evaluations of tree maintenance and risk. However, data collected by volunteers may be suitable for other management purposes. Urban forestry volunteers can provide reasonable accuracy for genus identification, particularly for common genera (Bancks et al. 2018, Bloniarz and Ryan 1996, Hallett and Hallett 2018, Hamilton et al. 2018, Roman et al. 2017). If more accurate species-level identification is required, professional field crews with excellent identification skills should be used.

When measuring **diameter at breast height** (d.b.h.), volunteers are generally within 1 inch (2.54 cm) of accuracy, which is acceptable for municipal arborists to describe size class distributions and contract for tree removal, but may not be acceptable for scientific studies of tree growth (Roman et al. 2017). Data collected by researchers and professionals are not infallible, but can be more consistent than data collected by volunteers (Bloniarz and Ryan 1996, Crall et al. 2011). Whether tree monitoring is conducted by researchers, professionals, interns, or volunteers, examining the extent and sources of error helps to identify best practices for training crews, conducting fieldwork, and managing data (Bancks et al. 2018; Hallett and Hallett 2018; Hamilton et al. 2018; Roman et al. 2017, 2018b; van Doorn 2014). We discuss tips for training and managing field crews that can promote data quality and effective data management in section 3.

One urban forest manager who conducts tree monitoring projects offered the following suggestion for other practitioners and researchers seeking to establish monitoring programs:

*“They need to know what the purpose is for the information. If you’re taking the time to do it, what’s the point? This helps drive what data you collect. Know who is going to do the work, and make sure they have the time and experience to do it properly.”*

(Roman et al. 2013)

## 1.4. Background

### 1.4.1. Development of the monitoring standards

The Resource Guide was developed by the Urban Tree Growth and Longevity (UTGL) working group and affiliated urban forestry researchers at the USDA Forest Service. The UTGL working group, founded in 2010, is part of the Arboriculture Research and Education Academy of the International Society of Arboriculture (Campbell et al. 2016, Scharenbroch et al. 2014). The working group’s mission is to foster communication among researchers and professionals; enrich scientific exchange; and enhance the quality, productivity, and timeliness of research on tree mortality, growth, and longevity through collaboration. This community of practice includes members (currently nearly 400) representing scientists, urban forestry professionals, and students.

The need for urban tree monitoring protocols and standardized data collection was identified at the first UTGL symposium at The Morton Arboretum (Lisle, IL) in 2011. As part of that event, attendees participated in a roundtable discussion on research priorities. Several of the top priorities related to standardized, comprehensive field-based monitoring protocols that would enable data sharing and collaboration (Leibowitz 2012). These desired protocols could detect change over time and across cities, while providing flexibility required by diverse users. That sentiment was echoed by respondents to a national survey of 32 local urban forestry organizations that already engage in urban tree monitoring. Staff at these organizations were asked about the goals, challenges, methods, and uses of their monitoring

programs; this information directly fed into the new protocols. Instead of “re-creating the wheel” and each developing their own monitoring protocol, respondents expressed interest in adopting a proven protocol (Roman et al. 2013), thereby freeing up scarce resources for other purposes and enabling comparisons across programs.

When asked for their recommendations for new standard protocols, survey participants suggested that the process should be inclusive and involve practitioners, and that protocols should be kept simple for users, rather than “complicated and academic” (Roman et al. 2013). Respondents also suggested that protocols should be adaptable to different organizational capacities and needs and noted that they would benefit from guidance from researchers and other organizations. As two participants expressed:

*“It would be helpful if the standardized protocols are developed with various respondents’ program designs/capacities in mind, that information is supplied suggesting the relevance/appropriateness of suggested protocols to the diversity of programs.”*

*“Our small organization does not have the capacity to do this research ourselves and search for and interview other programs. By providing information on what other programs do, suggesting protocols, and providing guidance, researchers could help us improve our work.” (Roman 2013)*

These research findings document the critical need and strong support for a monitoring standard. The Field Guide and Resource Guide respond to this need by providing guidance and field methods concerning long-term data collection.

From 2013 to 2014, an advisory group of several dozen urban forestry professionals, researchers, and students had regular conference calls and webinars to refine the protocols, facilitated by the UTGL working group. This approach was fundamentally bottom-up, with protocols responding to needs identified by local urban foresters, as group members included urban forest managers throughout the process. UTGL leadership emphasized an approach focused on co-learning across research and practice (Campbell et al. 2016).

Suggestions from survey respondents (Roman et al. 2013) formed a set of guiding principles for the development of protocols that meet the needs of most users:

- **Keep it simple.** Protocols should be straightforward, accessible to practitioners and managers, and relevant to organizations that rely on interns and volunteers for data collection.
- **Make it flexible and easily applied by a diversity of users.** Urban forestry practitioners collect monitoring data for a variety of purposes, so the protocols must be adaptable to different management needs.

- **Seek input from practitioners.** To ensure that the protocols will be relevant to local arborists, municipalities, nonprofit organizations, and other users, the protocol development process should seek frequent input from practitioners.
- **Answer key research questions.** There must be clear examples of how the data generated from this monitoring network can answer key research questions about urban tree mortality, growth, vigor, and longevity.
- **Promote management objectives.** Data collected should be useful for local practitioners to manage their urban forest resources.

With input from the many contributors to the UTGL protocols development team (see section 11) and the many authors of the Field Guide and Resource Guide, we drew on the knowledge of researchers and professionals who have years of experience designing and conducting longitudinal studies for both urban and rural trees (see Foreword). This addressed the guiding principle to be inclusive and involve practitioners. We kept the protocols simple yet flexible by establishing a Minimum Data Set (see Table 1 and section 6)—the smallest set of variables deemed necessary for longitudinal urban tree data—and four Supplemental Data Sets (see sections 7, 8, 9, 10). The Supplemental Data Sets are lists of variables that could be relevant for more time-consuming and skill-intensive data collection. This Resource Guide addresses the goal to answer research questions and address management objectives, including a discussion about goals that can be answered with field monitoring (section 1.1) and examples of how those goals are connected to data collection plans (section 1.4.3).

---

The Minimum Data Set is the smallest set of variables deemed necessary for longitudinal urban tree data.

---

#### 1.4.2. Connections to other urban tree inventory protocols

The field methods described here and in the Field Guide draw on existing methods, including **i-Tree Eco**, **i-Tree Streets**, and **Urban Forest Inventory and Analysis (UFIA)** from the USDA Forest Service. The i-Tree software suite is a set of free tools that assess the benefits provided by trees and forests in urban settings. Within the i-Tree suite, the i-Tree Streets and i-Tree Eco tools involve field data collection on individual trees. i-Tree Streets is intended to evaluate a complete or sample inventory of street trees. i-Tree Eco can be used to evaluate complete or plot-based sample inventories across the entire urban landscape including all land uses and site types. Both programs quantify the structure of tree populations and model the ecosystem services that trees provide (i-Tree 2017a, McPherson et al. 2005, Nowak et al. 2008).

UFIA is the urban expansion (Cumming et al. 2007, Nowak et al. 2016a, USDA FS 2020) of the USDA Forest Service's congressionally mandated ongoing forest inventory and monitoring across the United States through a national plot system, called Forest Inventory and Analysis (FIA). Traditional FIA did not include most urban landscapes, with the exception of areas within cities, towns, and suburbs that met the FIA definition of **forest land**—

**Table 1.—Summary of variables included in the Minimum Data Set for urban tree monitoring<sup>a</sup>**

Variable	Description
Field crew identification	Information about the individual(s) who collected field data on this tree
Field crew experience level	Experience level of the most experienced individual on the field crew
Date of observation	Year, month, and day of field data collection
Tree record identifier	Unique identifier that remains connected to the tree during future monitoring
Location	Information about the tree's geographic position in the landscape; several protocols available
Tree photo	A photograph taken to include the entire tree in the context of its immediate location and showing nearby built infrastructure objects
Site type	A description of the tree's immediate location
Land use	A description of the way the property around or adjacent to the tree is used by humans
Species	The species of the tree being monitored
Mortality status	A record of whether the tree is alive, standing dead, removed, or in some other state
Basal sprouts	Growths from the base of the trunk or in the roots (record only for standing dead trees and stumps)
Crown vigor	A holistic assessment of overall crown health which reflects the proportion of the crown with foliage problems and major branch loss
Trunk diameter	Diameter of the tree's trunk recorded at either 4.5 ft (1.37 m) or 1 ft (30.5 cm) depending on tree form, with many special rules
Height of trunk diameter	The exact height at which trunk diameter was recorded
Notes for supervisory review	Issues that cannot be resolved in the field; entering a note flags the tree for review by the project supervisor

<sup>a</sup> For the original table, see Table 1 in the Field Guide.

namely, areas at least 1 ac (0.4 ha), 120 ft (36.6 m) wide, 10 percent stocked with trees, and with undisturbed understories (Cumming et al. 2007, 2008; Oswalt et al. 2014). This means that some urban parks and forest fragments with dense tree cover are included in the traditional FIA plot system, but conventional FIA does not include isolated trees along streets, in parking lots, or in lawns. UFIA fuses methods from traditional FIA and i-Tree Eco. Austin, Texas, was the first city to have complete UFIA data (Nowak et al. 2016a), and several other states had served as precursors of UFIA (Cumming et al. 2008). The UFIA program is expanding to 100 cities across the United States (USDA FS 2020). Notably, FIA and UFIA plots are typically observed on a rotating panel system (e.g., all plots are visited over a 7-year period, at a rate of one-seventh each year, then repeating again), whereas all i-Tree Eco plots for a given city are typically collected over 1 or 2 years (although particular cities and states may follow different strategies for both i-Tree Eco and UFIA).

Of these three inventory protocols (i-Tree Streets, i-Tree Eco, UFIA), only UFIA is specifically designed for remeasurements of the exact same plots and longitudinal data collection to track individual trees. i-Tree Streets does

---

Plots which have not been permanently referenced cannot be reliably found again.

---

not provide protocols for longitudinal data collection. Plots collected with i-Tree Eco have sometimes been remeasured (e.g., Lawrence et al. 2012, Nowak et al. 2004), but Eco was designed to produce aggregate population and ecosystem services estimates at a single point in time, not to monitor tree demographic changes over time. i-Tree Eco plots which have not been permanently referenced (i.e., carefully recording information about plot center) cannot be reliably found again by future field crews. For example, plots collected in Philadelphia, Pennsylvania, in 1996 were not permanently referenced, and when i-Tree Eco was repeated for this city in 2012, new plots had to be laid out (Nowak et al. 2016b). Different size cutoffs that defined what trees to include in each inventory, in addition to the different sampling locations for the 1996 and 2012 data, precluded rigorous analysis of individual tree-level change over time. Other analyses of permanently referenced i-Tree Eco plots recorded in two or more different years have been able to report change metrics such as rates of mortality and growth, as well as species composition changes (Lawrence et al. 2012; Nowak et al. 2004, 2013b). See appendix 3 for descriptions of other inventory and monitoring protocols for urban trees.

---

Longitudinal data are needed for analysis of urban tree demography.

---

As mentioned previously, longitudinal data are needed for analysis of urban tree demography, such as change over time in mortality, growth, and health. While UFIA will fill this gap in long-term data in the coming years, with standard data collected across urban areas in the United States, it is a very intensive protocol that requires field crews to have certification in the methods, with exhaustive tree and plot data (i-Tree 2017a). Additionally, results from UFIA will also be most relevant at regional and state scales, while urban foresters often need data tied to specific planting initiatives or management programs (e.g., data for trees planted by a nonprofit or city planting campaign; data for neighborhood parks and recreation centers managed by a municipality). Urban forestry researchers and professionals may also be interested in focusing on a particular component of a city's urban forest, such as street, yard, or parking lot trees, owing to their distinctive governance structures, programmatic operations, and biophysical characteristics (Celestian and Martin 2005, Mincey et al. 2013, Nguyen et al. 2017). In these cases, randomly located plots across an entire city or metropolitan region, such as those in UFIA or i-Tree Eco, are unlikely to adequately represent the population of interest (e.g., street trees, yard trees) because the sample could be dominated by trees in natural areas. This is because trees in natural areas can make up a substantial portion of the overall urban forest. For example, for i-Tree Eco plots in Philadelphia, Pennsylvania, trees in parklands constituted over one-third of the trees inventoried even though parkland only covered about 9 percent of the city area (Nowak et al. 2016b). While parklands and natural areas are crucial components of the overall urban forest (Pregitzer et al. 2018), if managers seek data reflecting their other program or mission areas, different sampling strategies are appropriate. Standard methods and practical guidance are needed for managers and researchers seeking to embark on their own urban tree monitoring projects.

With regard to urban tree data already collected by local practitioners, municipal foresters and nonprofit staff manage their inventories and monitoring programs for different purposes, such as asset and tree risk management, assessing planting program performance, evaluating species diversity and size class distribution, and engaging the public (Bond 2013, Harris et al. 2004, McPherson and Kotow 2013, Roman et al. 2013, Sjöman et al. 2012). Such management-oriented inventory data are not necessarily collected in a manner conducive to analysis of demographic rates of change. For example, if the trunk diameter is recorded to the nearest 1 inch (2.54 cm) and the exact height at which the diameter is taken is not noted—a common situation in many municipal tree inventories—then the data are not precise enough to support analyzing tree d.b.h. growth (i.e., radial growth of the trunk), even though the records are certainly useful for municipal arborists to manage tree inspection cycles and removal work orders. Tracking tree location is also challenging. In conventional municipal tree inventories, location has often been recorded in ways that prevent field crews from finding all trees based on data from several years prior. For instance, municipal tree inventories or planting records may use only an address to denote location, yet there can be more than one tree per address. Field crews may not know whether a tree that seems to be “missing” was removed since the previous inventory, or was merely not found owing to insufficient location information. Some approaches to recording street tree inventories, such as the address and site code method (see Field Guide section 2.4.1), can be cumbersome to update with each new year of data collection, particularly as trees get added and removed, which disrupts the site code ordering (see section 2.3 for a discussion of pros and cons of various location methods for monitoring). Furthermore, data precision and data quality issues are different in longitudinal data compared to static inventories. We explain more about the rationale for recording particular variables in specific ways for monitoring projects in section 6. Urban forest practitioners wishing to assess tree mortality, growth, and health may need to modify their established data collection protocols to analyze change over time.

---

The Field Guide and Resource Guide lay the foundation for practitioner-driven long-term studies of tree mortality, growth, and health.

---

Our Field Guide and Resource Guide lay the foundation for practitioner-driven long-term studies of tree mortality, growth, and health. In the Field Guide, we emphasize simple user-friendly explanations for volunteers and interns, precise location information for varied circumstances, and consistent measurements of tree size to facilitate growth analyses. Additionally, because we recognize that there is a wide range of user needs and resources for monitoring, and that long-term monitoring is not necessarily embedded in the design of most city tree inventories, this Resource Guide provides tips and strategies for planning and managing long-term data collection. Studies about urban forest change over time using field data are relatively recent in the urban forestry literature, meaning that procedural issues of longitudinal data collection and management are only now getting attention.

### 1.4.3. Examples of the Field Guide in action

The field methods described in the Field Guide have already been used and adapted by urban forestry researchers and professionals. We share examples here to provide tangible guidance as to how these standards work in action.

- **Residential yard tree monitoring.** Researchers at Clark University, in collaboration with the Massachusetts Department of Conservation and Recreation, supervised undergraduate interns monitoring trees planted by the state in residential yards as a reforestation project following removal of trees because of Asian longhorned beetle (*Anoplophora glabripennis* [ALB]) quarantine (Bird 2014, Elmes et al. 2018, Hostetler et al. 2013). This was a planting cohort monitoring project with a goal of assessing what factors are related to young tree mortality outcomes, with particular interests in socioeconomic and built environmental factors. The project used the Minimum Data Set and linked tree locations to neighborhood socioeconomic variables, in addition to tree and site characteristics, to analyze mortality outcomes. Student researchers conducted interviews with study participants to assess residential motivations for tree planting, perceptions of tree loss from ALB, and gains from the new planting initiative (Goldman 2017).
- **Shade tree survival audits.** The Energy-Saving Trees program of the Arbor Day Foundation distributes free shade trees to private residences across the United States in partnerships with utility districts (Arbor Day Foundation 2018). To assess survival, Arbor Day Foundation staff collaborated with the Texas Forest Service to audit trees given away in the Houston area; fieldwork was carried out by professional foresters. This was a planting cohort monitoring project with a goal of providing summary information about tree mortality and growth, as well as determining the extent to which participants were maintaining their yard trees. In addition to the Minimum Data Set, field crews collected data about residential maintenance practices, borrowing methods from the Planted Tree Re-Inventory Protocols developed by researchers at Indiana University–Bloomington (Vogt and Fischer 2014).
- **Citizen science street tree monitoring.** The Tree Checkers program at Pennsylvania Horticultural Society used volunteers to monitor recently planted street trees in Philadelphia (Roman et al. 2018b). These volunteers were already engaged in tree stewardship through the Tree Tenders planting program. The monitoring goals were to produce planted tree mortality rates as a metric of program performance, while also engaging local communities in ongoing stewardship. TreeCheckers staff updated their methods based on standards in the Field Guide. A similar citizen science monitoring project was developed by the Pennsylvania Department of Conservation and Natural Resources to track young street tree survival in tree planting projects they fund across the state; a pilot test was conducted in Harrisburg, PA (Pennsylvania Urban and Community Forestry Council 2018). In addition to the Minimum Data

Set, both of these projects recorded information about maintenance practices, based on recommended stewardship actions from those planting programs. Similar to the Arbor Day Foundation example, the planting program staff in Pennsylvania wanted to check how closely program participants followed tree care instructions. Tree Checkers also paired the data collection with carrying out routine maintenance actions as well as “report cards” to residents with reminders about stewardship. These tasks were all carried out by volunteers.

- **Pilot test about volunteer data quality.** To evaluate the draft Field Guide, and, in particular, its potential application to minimally trained field crews, a study was conducted about volunteer data quality in urban tree inventories (Roman et al. 2017). This project involved citizen scientists in four cities (Lombard, IL; Grand Rapids, MI; Philadelphia, PA; Malmö, Sweden). Results showed that volunteer data quality would be appropriate for some uses of tree inventories and monitoring, but not others. The findings also indicated which variables had particularly low data quality (e.g., crown transparency and wood condition) and should be dropped from the protocols, as well as particular challenges for other variables like d.b.h. for multi-stem trees.
- **Plots for street tree health monitoring.** For long-term monitoring of urban tree health, street tree plots were established in New York City and Philadelphia, with each plot consisting of several adjacent block segments. The project goals were to understand long-term changes in street tree populations, composition, and health, including crown vigor. This project was a collaboration between the USDA Forest Service Northern Research Station and The Nature Conservancy’s Healthy Trees, Healthy Cities initiative. The project was set up to allow for re-inventory of sampled plots; thus far, only the baseline data have been collected. In addition to the Minimum Data Set, interns collected data about foliage health. Forest Service scientists and program staff from The Nature Conservancy closely supervised the interns.
- **Public tree inventory and monitoring in Hawaii.** The Citizen Forester Program was created by the State of Hawaii Division of Forestry and Wildlife as an effort to engage communities in their urban forest and fulfill a key strategic goal in Hawaii’s Forest Action Plan, the development of an urban tree inventory. The purpose of the urban tree inventory is to facilitate management including maintaining and replacing trees and planning for disasters. Community volunteers are trained to collect tree data and work with a team leader, while a certified arborist ensures quality control of the data. Mapped trees along streets and in public parks are displayed through an online map tool (<https://pg-cloud.com/hawaii/>) displaying species and d.b.h. Developers of the program took advantage of the Field Guide’s modular design by collecting some of the Minimum Data Set but also including maintenance and condition variables to meet their goals.

- **Climate-ready trees project.** The goal of the climate-ready trees study is to evaluate the tolerance of underutilized tree species to stressors associated with climate change, especially drought, by tracking their mortality, growth, and health (McPherson et al. 2018). The study is being conducted in three climate regions of California (Inland Valleys, Inland Empire, and Southern California Coast) and is expected to run for 20 years. Trees were selected for testing because of their apparent resilience to stressors such as heat, drought, high winds, salinity, and pests, as well as suitability in urban environments with respect to potential hazard to people and infrastructure. As part of this planting cohort monitoring project, tree species replicates were planted in reference sites on university experimental stations as well as urban parks, which will allow for direct comparisons of growth and survival under a range of site conditions. In addition to the Minimum Data Set, aspects of Tree, Site, and Young Tree Management Data Sets have been incorporated into the monitoring protocol. Trees are monitored yearly for mortality status, growth (d.b.h., total height, crown width), and suitability as urban trees (e.g., arboricultural/structural characteristics, health issues, presence of pest and disease, maintenance needs).
- **Undergraduate urban forestry course.** For an urban forestry course at the University of California, Davis, instructors use components of the Field Guide to teach inventory and monitoring methods. Learning objectives include how to use standard equipment, how to ask questions and answer them with data, and how to get accurate and repeatable data to assess change through time. Material from the Field Guide was adapted for a student group assignment to conduct a tree inventory and site assessment, with students using those data to write a scientific-style report (M.L. Cadenasso, pers. comm.).

## 2. Getting Started

### 2.1. Planning Ahead for Data Collection, Management, and Analysis

---

Establishing and continuing urban tree monitoring projects requires advance planning.

---



---

Collecting an exhaustive set of variables—the “laundry list”—can be counterproductive.

---

Establishing and continuing urban tree monitoring projects requires advance planning. Having clear project goals, data collection and management protocols, and intended analyses planned in advance are critical to any ecological monitoring endeavor (Lindenmayer and Likens 2010a). Below, we list 18 key steps that anyone running an urban tree monitoring project should undertake before training and data collection begin.

#### 2.1.1. Articulate clear and achievable goals for your urban tree monitoring project

These goals will determine what variables you collect and help to decide whether your project should expand beyond the Minimum Data Set. See section 1.2 for potential goals of urban tree monitoring and section 1.3 for examples of connecting goals to methods.

#### 2.1.2. Finalize the suite of variables to be collected in the field

This is determined based on project goals, field crew skill level, and available resources (e.g., funds for specialized equipment and professional field crews). Projects using citizen scientists may need to adjust their goals to focus on data that volunteers with minimal prior experience can collect properly (Bancks et al. 2018; Hallett and Hallett 2018; Hamilton et al. 2018; Roman et al. 2017, 2018b). Projects using arborists certified by the International Society of Arboriculture or specialized researchers can potentially record more variables, although it should not be assumed that such expert data are infallible or always consistent across expert observers (Bloniarz and Ryan 1996, Koeser and Smiley 2017, Roman et al. 2017, Westfall and Woodall 2007), or that every expert is well-versed in all necessary field methods. Every variable collected should have a clear purpose related to the project goals and data analysis plans (section 1.3). Collecting an exhaustive set of variables—the “laundry list”—can be counterproductive in that such an approach takes focus (and resources) away from the variables that matter most for intended analyses (Lindenmayer and Likens 2010a).

#### 2.1.3. Determine the best method for recording tree location in your study

In this Resource Guide, we offer guidance about location methods for trees in various site types, including pros and cons of each method (section 2.3), and we give more detailed protocols for a few of those location methods in the Field Guide (section 2.4). The best location methods for your project will depend on what site types may be encountered, field crew expertise,

and available data collection equipment (especially paper versus mobile data collection). We recommend the use of several complimentary methods of recording location, including photos of every tree when feasible, to ensure that individual trees can be reliably found in future years.

#### **2.1.4. Make a plan for sampling your trees**

While some projects might sample all trees from a planting cohort, or conduct a complete census of all trees in a geographic area, this may not be logistically feasible, so many monitoring projects will need to select a sample. For example, the monitoring project could use a random or stratified subsample of all trees planted through a particular initiative over the span of several years. Alternatively, the monitoring could be associated with a total street tree inventory or with a plan to re-inventory the trees in future years, perhaps associated with maintenance/inspection cycles, or randomly selected street segments. Depending on the project goals, sampling design may also have to take into consideration target species, species functional types, geographic areas (e.g., ZIP codes, planning districts) or neighborhood characteristics. The sample design and sample size also affect statistical analysis options for the project. For municipal arborists and nonprofit program managers, we recommend contacting researchers or graduate students at universities and the Forest Service for advice regarding statistical sampling strategies for your specific project.

#### **2.1.5. Estimate the time required for data collection and transportation**

Based on the pilot test of the Minimum Data Set, recording that small suite of variables requires approximately 3 minutes per tree (Roman et al. 2017). Recording additional information about site characteristics requires approximately 5 minutes (Scharenbroch et al. 2017). Neither of those estimates included transportation time, but the geographic spread of tree locations can drastically influence the transportation time required for fieldwork. For example, monitoring hundreds of street trees within a single neighborhood will require little transportation time and could be achieved in a matter of weeks, but monitoring hundreds of private yard trees or plots spread across a large city or metropolitan region will have longer transportation times and likely take several months. For studies involving residential yard trees and other private properties, communicating with residents or property managers to gain access to their land can drastically lengthen fieldwork time required. Some cities may also have challenges with excessive rush hour traffic and difficulty finding parking, so the project supervisor needs to select the most productive strategies for fieldwork timing (e.g., begin before rush hour) and mode of transportation (e.g., car, bicycle, public transit).

### **2.1.6. Decide how the term “tree” will be defined for your monitoring project**

There is no broadly accepted definition for “tree” in botany or forestry (Gschwanter et al. 2009, Lund 1999). See section 2.2 for possible definitions of “tree” in urban tree monitoring. Select the definition of tree for the particular monitoring project and explain it to your field crews. Confusion over this issue can introduce substantial errors in the monitoring, as crews may be unclear which plants are “in” or “out” of the study (Roman et al. 2014b, 2017). This can lead to problems quantifying mortality rates and net changes to total tree counts (i.e., population growth rates). Similarly, urban foresters may be interested specifically in “street trees” or “public trees,” but the use of these terms can vary across and even within municipalities, so project supervisors need to clearly and simply define them (see section 2.2).

### **2.1.7. Select the data collection system**

Optimal data collection systems will differ by the purpose and needs of each project. Although many urban foresters have moved to mobile data collection systems, paper might be preferable in some cases—for instance, when doing a citizen science inventory with volunteers who do not have smartphones or tablets. Furthermore, while there are many software packages for urban tree inventories, they are generally not designed for longitudinal data collection (Boyer et al. 2016). For more information about the pros and cons of paper versus mobile data collection and further discussion of software packages, see section 2.6.

### **2.1.8. Determine the type of monitoring project**

As previously discussed, there are two general types of monitoring projects addressed in the Field Guide and the Resource Guide (see section 1.2): planting cohort monitoring and multi-age inventory monitoring. The study type chosen should be kept in mind when comparing to other monitoring studies. For instance, mortality and growth rates in a street tree planting cohort monitoring project should be evaluated in relation to other street tree planting cohort studies, preferably with a similar time period post-planting. Likewise, a repeated inventory of sampled i-Tree Eco plots is most appropriately compared to other plot-based repeated inventory studies.

### **2.1.9. Ensure that baseline records are complete and have high data quality**

Baseline records are the first set of tree data relevant to the monitoring project—the starting point from which comparisons will be made going forward—and good baseline records are essential for continued data collection. For planting cohort monitoring, the baseline records are at-planting data (Vogt et al. 2015b). The “at-planting” records must include the planting date, preferably an actual date rather than a year or season (e.g., spring 2017). For multi-age inventory monitoring, the baseline records are the first inventory. Planting date is not strictly necessary for multi-age

---

Baseline records are the first set of tree data relevant to the monitoring project.

---

inventory monitoring. Nonetheless, planting date, or more broadly tree age, would be helpful in that situation as well, if available. Tree age can be obtained from municipal tree records, interviews with urban foresters and homeowners, and tree core increments. Programs interested in tracking population cycles may also want to record tree removal date. For any monitoring project, if the baseline records were not originally collected with monitoring in mind, considerable time should be spent inspecting those records to ensure that they can be used for monitoring. For instance, if location data involved only addresses, then crews may not be able to locate individual trees in the field (see section 2.3 for a discussion of pros and cons of various location methods). Organizations may need to adjust their approach to baseline records to enable monitoring. If baseline records for tree locations, species, or other variables are incomplete or inaccurate, then project supervisors and field crews will need to clean up the data, and excessively messy records may be ultimately unsuitable for monitoring. It is important to understand the data quality of each variable in the baseline records and ensure that the observations regarding data quality match the specifications for the monitoring project, including acceptability thresholds for each variable (see section 2.1.13).

#### **2.1.10. Decide whether field crews will measure in metric or U.S. customary units and level of measurement precision**

Ensure consistency and always note on the data sheet or in the mobile data collection system which units are being used. The same units should be used by all crews and across all equipment and throughout different monitoring years. Although metric units (e.g., meters and centimeters) are the norm in scientific research, urban forest managers in the United States typically use U.S. customary units (e.g., feet and inches), and a particular monitoring project might be bound to using certain units owing to available equipment. Similarly, decide whether trunk circumference versus d.b.h. will be measured. While recording trunk diameters is the norm in forest ecology research, some municipal foresters and nonprofit staff may prefer to record circumference at breast height owing to available equipment. While we strongly recommend recording trunk diameter, if circumference is recorded, this must be noted to enable conversions later. Additionally, project supervisors will need to decide what level of measurement precision is needed. When recording d.b.h., we recommend recording to the nearest millimeter or tenth-inch. However, some urban forestry professionals only have equipment to measure to the nearest half-inch or quarter-inch. Such equipment is not conducive to analyzing individual tree growth rates but can still be used to group trees into size class categories. If using U.S. customary units, we recommend using equipment with tenth-unit graduations, as this is easier to record than other graduations (e.g., tenth-inches instead of quarter- or eighth-inches for measuring tapes; tenth-feet instead of feet and inches for height poles). We also specify in the Field Guide that height to the d.b.h. measurement point should always be recorded for every tree. This is because

---

Note which units of measurement are being used.

---



---

Height to the d.b.h. measurement point should always be recorded for every tree.

---

(a) while 4.5 ft (1.37 m) is the norm in the United States, different default heights can be used both within the United States and around the world (Brokaw and Thompson 2000), and (b) d.b.h. can be recorded at different heights owing to tree form, such as low-forking multi-stemmed trees (see section 6.6 for more information about challenges of measuring d.b.h. in urban settings). Whatever units are chosen, the decision should be noted in a data dictionary or **metadata** accompanying the raw field data.

#### **2.1.11. Decide on level of detail for species identification and species codes**

For multi-age inventory monitoring projects, crews will need to identify tree species in the field, whereas for planting cohort monitoring projects, crews will need to confirm species based on the at-planting records. Some trees are difficult to identify to the species level, even for the keenest eye. Common urban genera that are difficult to identify to the species level include crabapples (*Malus* spp., code MALUS), ornamental cherries and plums (*Prunus* spp., code PRUNU), and hawthorns (*Crataegus* spp., code CRATA). These should be entered as genera only unless there are clear records of which species, hybrid, or cultivar was planted. Note that for mobile interfaces with a drop-down menu of tree species, this means that there should be an option for genus-only identification (e.g., MALUS, PRUNU, and CRATA). In addition, less experienced field crews might have trouble with other genera, so supporting a genus-level identification may be necessary unless the objectives of the study do not allow for that level of coarseness. For instance, if crews are confident that a tree is a maple, but unsure which species, they could record only the genus (*Acer* spp., code ACER). Having an option for “unknown” for genus and species identification is also wise to enable crews to note where they are unsure. Another option is to add categories such as “unknown broadleaf” and “unknown conifer.” Species or genus identification, coupled with information about the size of the tree, can be suitable for making inferences about tree biomass and ecosystem services (McPherson et al. 2016). For planting cohort monitoring, the at-planting data may include species and even cultivar, so that level of detail could be included in analysis. Additionally, projects will need to use species or genus names consistently (and cultivar names, if used). When using species codes, we recommend the codes from the UFIA program (i-Tree 2017a), see Field Guide section 2.8.

#### **2.1.12. Decide how crew will investigate and resolve unknown species**

Species identification of urban trees can be a challenge, as there are many native and exotic species. Strategies, guides, or tools for identifying unknown species will depend on the protocol set by the supervisor regarding which information to record and what documentation to note for the supervisor. Options for resolving unknown species include field guides to be used onsite, taking leaf samples to examine further in the office, taking detailed photos to send to experts, and mobile leaf apps for species identification

(see appendix 2 for a list of species identification resources). Because the technical expertise required for using species identification field guides differs, crews may need training in using the guides. Supervisors may wish to prepare a customized guide for their project with common tree species for their city or region. If pictures are taken for identification purposes, include images of leaves; fruit, nut or flower; bark; and the whole-tree profile. These photos should be labeled with the tree record identifier; if using paper data sheets, a blank sheet of paper or mini white board is handy for using a backdrop to display the tree record identifier. Additionally, information about the environmental conditions in which the tree is growing (e.g., wet or dry), where it is located in the landscape, and whether the tree appears to have been planted or naturally occurring can help inform species identification. If enough of the specimen tree is present, and it is permitted, field crews may want to collect physical leaf samples, in which case they will need paper bags and a permanent marker for recording the tree record identifier.

### 2.1.13. Set acceptability thresholds for each variable

Different projects will have different needs for the accuracy and precision of each variable, as alluded to in the earlier discussion of species identification (section 2.1.11). As expressed by Loshin (2011), writing about data quality for businesses, “[the] acceptability threshold is the point at which measured noncompliance with user expectations may lead to material business impact.” In the urban forestry context, acceptability thresholds relate to intended uses of the data in management or research. Setting acceptable levels of inconsistency or error for each variable provides guidance when evaluating field crews during training or **quality control** checks (see sections 3.1.2 and 3.2). For instance, Roman et al. (2017) suggested that d.b.h. measurements by volunteers that are within  $\pm 1$  in ( $\pm 2.54$  cm) of expert measurements are acceptable for most management applications, whereas a d.b.h. tolerance threshold of  $\pm 0.1$  in ( $\pm 0.254$  cm) is appropriate for most scientific research. Notably, UFIA sets data quality standards for genus, species, d.b.h., and many other variables (USDA FS 2016). The FIA and UFIA programs refer to measurement repeatability, which takes into account the acceptable range of differences between measurements (i.e., tolerance) and the acceptable proportion of differences within that tolerance (i.e., measurement quality objectives [MQO]). The tolerance threshold must be met for a proportion of the observations for the data quality goal to be achieved. An evaluation of adherence to MQO for coarse and fine woody debris (which serve as fuel for forest fires) was described in Westfall and Woodall (2007); many variables did not meet the desired repeatability levels. Kitahara et al. (2009) described consistency between field teams and control teams for the Japanese National Forest Inventory, and again many variables did not meet the MQO thresholds set for FIA data. Therefore, it is important to note that even professionally certified crews do not produce flawless data. The acceptability thresholds for a given project should consider both the data quality needs of the intended analyses as well as the practicality of reproducibility among crews.

---

Acceptability thresholds should consider both data quality needs and reproducibility among crews.

---

#### 2.1.14. Decide whether to track planting sites, trees, or both

Some monitoring projects will track the mortality, growth, and health of a group of trees, without concern for replacement plantings when trees are removed. Other projects may focus on planting sites, such as sidewalk cut-outs (also known in some regions as “tree pits”), which may have a series of trees through the years, but the geographic location of the planting site remains constant, and the maximum number of trees at the site is one. That site is tracked through time and monitored even when the tree pit is empty. Tracking street tree sites is relevant to planning and management (e.g., stocking levels, planting needs) and could be used for multi-age inventory monitoring projects, particularly for monitoring replacements (see section 2.1.15). Additional information (e.g., overhead utility conflict, soil characteristics) may be collected about the site regardless of the presence/absence of a tree to help inform management activities. Decisions about whether to track sites, trees, or both affect the structure of the longitudinal database for a monitoring project and the assignment of **primary** and **unique keys** (see section 2.5.1).

#### 2.1.15. Decide how to deal with replacement trees

---

Replacement trees are trees planted in the exact same location as removed trees.

---

Replacement trees—defined here as trees planted in the exact same location as removed trees—can be of interest for street tree management, where the possible locations of trees are relatively fixed. Municipal street tree planting contracts may include a replacement requirement, with contractors responsible for replacing dead trees within a few years after planting. Likewise, nonprofit programs tracking the street trees that they plant can use monitoring data to generate replacement requests. Noting that a tree is a replacement planting can be part of planting cohort monitoring studies (if there is interest in tracking the replacement trees, not simply the original planting cohort). Tracking replacements for either planting cohort monitoring or multi-age inventory monitoring projects can also help managers recognize that certain sites are continually losing trees and therefore could be declared unsuitable for planting. Researchers also may be interested in tracking replacement rates, as these can reveal trends in stocking levels and species selection preferences as well as inform tree population projections (van Doorn and McPherson 2018).

#### 2.1.16. Decide how to deal with “zombie trees”

By the criteria presented in the Field Guide for mortality status (see Field Guide section 2.9), for a tree to be classified as standing dead, it must have no green leaves, no live buds, and no green tissue under the bark. In practice, it is fairly easy to confirm the first two criteria for smaller trees, but much more difficult to confirm absence of green tissue, particularly on larger trees. Given the possibility that recently defoliated trees may have remaining resources to releaf and survive, inconsistencies in mortality status cannot be completely eliminated. Thus arises the issue of “zombie trees”—which we define as trees recorded as standing dead in one field visit (e.g., time 0) but alive in the next field visit (e.g., time 1). If any “zombie trees” are observed

at time 1, a possible database solution is to create a corrected mortality status column for time 0 and change the designation to alive. In other words, a tree that was previously thought to be standing dead at time 0 would be corrected to alive to reflect information learned at time 1. A similar but separate issue arises when trees are planted (or naturally regenerate) but then get removed before they can be added to the monitoring project—in other words, a tree that was planted but then removed so quickly that the monitoring field crews did not get a chance to observe it. These are referred to as “ghost mortalities” (Sheil 1995, van Mantgem and Stephenson 2005). Some studies specify the ghost mortality rate and report it as part of the error rate (van Doorn et al. 2011). Occurrences of “zombie trees” and “ghost mortalities” are rare overall, but because they can affect mortality rate calculations, project supervisors should think about how to deal with these situations ahead of time.

### **2.1.17. Decide the intended use of the basal sprout variable**

The intended use of basal sprout variable (see Field Guide section 2.10) may vary depending on project goals. Monitoring **basal sprouts**, for example, may change the way managers choose to code mortality status (see Field Guide section 2.10). For management purposes, trees that are dead in the main stem should be removed in most situations, especially large dead trees that could cause damage to people or infrastructure, regardless of whether basal sprouts are present. Our definition of mortality status categories in the Field Guide reflects this real-world understanding of a “dead” tree, with trees that are dead in the main stem, but have living basal sprouts, categorized as standing dead. Yet, technically, if basal sprouts are present on an individual tree, that organism is not truly dead. A “new” tree can even emerge from the sprouts. For instance, we have seen cases of recently planted trees that are dead in the main stem, but have basal sprouts, get left alone (i.e., not removed) in residential yards, neglected streets, or experimental plots, and then grow back into full trees from a sprout. Such trees can have large canopies, but they might not necessarily grow into attractive forms. Figure 1 shows an example of a sprout growing into a full tree from a monitoring study of experimental plantings for climate-ready trees (McPherson et al. 2018). Although the tree is still the same living organism, according to our way of recording mortality status (see Field Guide section 2.9), the stem emerging from the basal sprout would get recorded as a new or replacement tree. Considering studies focused on d.b.h. growth, recording the emergent basal sprout as a new tree would be helpful because it does not make sense to directly compare the diameters of the old dead main stem and the new stem growing from a sprout. However, if a researcher wanted to record mortality in the strictest sense—with trees needing to be “all the way dead” to count as mortality—then a tree with a dead main stem but living basal sprouts would be considered alive. In this case, an analyst would need to re-code Mortality Status to reflect the different use of the basal sprout variable.



**Figure 1.**—*Parkinsonia* x “Desert Museum” planted at University of California, Davis, is an example of a basal sprout that has regrown into a new main stem. In 2015, the *Parkinsonia* x “Desert Museum” (A, tree in the forefront) was alive and the main stem was intact. The tree was recorded as mortality status alive. By 2016, the main stem had broken off (B) and a small sprout was growing. The tree was recorded as a stump, with basal sprout present. In 2018, the sprout increased in size (C) and had many leaves and flowers, resulting in it being the new main stem. The sprout received a new tree record identifier and was recorded as alive in 2018 with a note about its sprout origin and the tree record identifier of the original stem. Making note of these details allows for this situation to be more easily filtered out depending on the analysis. The notes for supervisory review variable in the Minimum Data Set was designed to capture this sort of unusual situation (see Field Guide section 2.13).

---

Being able to identify the strange but rare cases allows for more informed decision-making in monitoring studies.

---

Challenges from basal sprouts in interpreting mortality results are relatively infrequent in urban tree monitoring, yet these rare challenges can vex field crews and analysts, so we raise this topic to encourage project supervisors to carefully consider how basal sprouts on otherwise dead trees will be handled. Being able to identify the strange but rare cases allows for more informed decisionmaking in monitoring studies.

### **2.1.18. Design a spreadsheet or database to organize the monitoring data**

A well-designed spreadsheet or database is crucial for organizing the collected data and enabling analysis, and it is important to plan how to organize the data before data collection begins. Broman and Woo (2018)

suggested general guidelines for data organization in spreadsheets, and many of their recommendations will probably be familiar to urban foresters that have dealt with tree inventory data. Their guidelines include the following: be consistent (particularly with variable naming conventions, codes for categorical variables, and dates), use a code for missing values (rather than leaving cells blank), and create a data dictionary (also called metadata). Designing a spreadsheet or database also involves setting up primary and unique keys (see section 2.5.1). There are further considerations for monitoring projects that produce longitudinal data. In particular, it is important to decide on tabular data presentation: long versus wide format (see section 2.5.2). For particularly large or complex data sets, it is advisable to create a master data set stored in a repository maintained by one or a few select people so as to minimize the possibility of contamination. To conduct analyses, the desired data may be extracted from the repository into a working file. Any errors detected in the working file should be brought to the attention of the person(s) responsible for maintaining the master copy to resolve the issues.

## 2.2. What Is a Tree?

The word “tree” does not have a standard botanical definition (Gschwantner et al. 2009, Lund 1999). Although “tree” is generally taken to mean woody plants with secondary growth (i.e., the trunk thickens each year by growing outwards) and a distinct crown, there are various ways to define “tree” or to delineate which “trees” to monitor for a study. For example, palms are not considered to be “trees” by typical forestry definitions, yet palms are managed as trees in many urban forests. Note that including palms would also necessitate modifications in recording growth and vigor, as methods suitable for deciduous trees and conifers do not translate to palms (Blair et al. 2019). For instance, monitoring studies for palms seeking to characterize growth should consider growth in total height, as d.b.h. growth and canopy width growth are not biologically relevant.

Other “tree” definitions relate to the number of stems, with trees typically considered to be plants that have one main stem, and mature height of the plant, with trees being taller than shrubs. Shrubs are often distinguished from trees by their multiple trunks and shorter height, but there is not necessarily a strict height cutoff. In urban forestry, some vegetation that would be considered a “shrub” owing to growth habit (i.e., multiple “trunks”) may be pruned into a “tree,” adding to the confusion. Examples include serviceberry (*Amelanchier* spp.), crape myrtle (*Laegerstroemia* spp.), and Spanish dagger (*Yucca* spp.). Differences in which plants are included in urban forest monitoring projects could make comparisons across cities and programs difficult, and neglecting to define “tree” for a project can lead to inconsistencies in field data.

---

Neglecting to define “tree” for a project can lead to inconsistencies in field data.

---

One way to define “tree” for purposes of an inventory or monitoring project is to set minimum sizes for height and d.b.h. that exclude both shrubs and tree saplings, as is common in rural forestry research. Plot-based inventories

and repeated census studies in urban forestry have followed that precedent. For example, FIA in rural forests has traditionally recorded trees with d.b.h. at least 5 inches (12.7 cm), with recent incorporation of saplings down to 1 inch (2.54 cm) for microplots (McRoberts et al. 2005). A similar approach has been used for the i-Tree Eco protocol for urban forestry plots, which calls for recording all woody stems at least 1-inch (2.54 cm) d.b.h. (i-Tree 2017a).

Yet the approach using size cutoffs to define what “counts” as a tree can also become problematic, leading to species commonly considered to be “shrubs” to be declared the most common “tree” in urban forests. According to an i-Tree Eco study in Philadelphia, PA, spicebush (*Lindera benzoin*), generally considered a shrub, is the most common tree (Nowak et al. 2016b). A similar finding occurred in Chicago, IL, where European buckthorn (*Rhamnus cathartica*) was the most common tree (Nowak et al. 2013a). Additionally, using a 1-inch (2.54-cm) cutoff in urban forests excluded some small, recently planted trees that are highly important to managers and researchers studying the establishment phase. Conversely, for some managers and researchers, these small trees may be less relevant, as they are not yet large enough to provide substantial environmental benefits. An advantage of the 1-inch (2.54-cm) cutoff is that this approach can be relatively straightforward for field crews to understand and consistently implement. Remeasurements of i-Tree Eco plots have successfully used the 1-inch (2.54-cm) cutoff to assess change over time when the plots were permanently referenced (e.g., Lawrence et al. 2012, Nowak et al. 2004).

A strategy to prevent plants that are viewed as “shrubs” from being recorded as “trees” is to limit data collection to a predetermined species list, composed of species generally considered by researchers and managers to be “trees.” With this approach, field crews would receive a list of species that are eligible for inclusion in the study. This strategy can also align with training and productivity for field crews, as their identification tasks are limited to a predetermined group of species. The UFIA program employs this strategy in addition to a d.b.h. cutoff. UFIA species lists for different regions of the United States are available in the UFIA Field Guide (i-Tree 2017a). Alternatively, crews could receive a list of species to be excluded that are not considered “trees” for purposes of the study at hand. For example, instruct crews to record trees with at least 1-inch (2.54 cm) d.b.h., but exclude certain shrubby species (e.g., exclude spicebush in Philadelphia, PA, and European buckthorn in Chicago, IL).

Another potential source of confusion occurs in monitoring studies that are focused on street trees. What managers define as a “street tree” may vary across cities and even within cities. For instance, street trees could be limited to trees in sidewalk spaces that have planting cutouts or planting strips; such spaces may be the dominant kind of street tree in road networks that feature sidewalks. Yet other streets and roads that lack sidewalks may have trees planted in front yards that are considered street trees owing to their placement within the public **right-of-way**. Even when there is a sidewalk,

a tree located on the building side of the sidewalk might be considered a private property tree, or a public municipal street tree, depending on local context. A street tree repeated census study in Oakland, CA, addressed this challenge by using a very restrictive definition of street trees: only trees located between the sidewalk and the curb were included (Roman et al. 2014b). Yet this very restrictive street tree definition is only an option when all streets have sidewalks.

For a street tree multi-age inventory monitoring study, project managers will need to decide (1) whether “tree” has a minimum d.b.h. cutoff, predetermined species list, or both, and (2) whether “street tree” is defined by right-of-way versus relationship to sidewalks and medians. For planting cohort monitoring of street trees, “tree” can be defined much more simply as all the individuals planted through a particular program. The eligible species would be determined based on what species were in the planting records. Such projects would not need to have a minimum size threshold for trees to be included in the study because the trees under consideration are all of the individuals from the planting program, regardless of current size.

Whichever choice is made, it is important to pick a definition of “tree” and remain consistent throughout the monitoring study. Lack of a clear and consistent definition of “tree” can lead to a confused interpretation of change over time owing to discrepancies over which plants are included and excluded from the study. This can lead to crews having different population counts (Roman et al. 2017), or analysts may need to amend baseline records to make the meaning of “tree” more consistent (Roman et al. 2014b), making it challenging to interpret findings about changes in total population size and potentially introducing error into calculations of mortality, growth, and health. In Table 2, we offer potential definitions of “tree” for different types of monitoring projects.

### 2.3. Choosing the Appropriate Location Method

---

The use of several complimentary methods for recording location will ensure that individual trees can be reliably found.

---

Location information is used to reliably locate the same trees across time and to connect tree field data to other geospatial data sets. Geographic location is one of the most essential pieces of data for monitoring; without an accurate location, a tree cannot be found for remeasurement, and a tree’s data cannot be connected to future and past observations. Below are guidelines on appropriate location methods for various site types. We recommend selecting at least two complementary location methods. If there is a problem with one method, the other method is available as a backup to help future crews find the tree. For example, a crew might locate a street tree using address and site code and also note highly accurate latitude and longitude coordinates with a global positioning system (GPS) receiver. Whenever possible based on program capacity, we recommend identification tags, to-scale site maps, or highly accurate GPS units (i.e., submeter accuracy). We also strongly encourage photos of every individual tree, preferably showing semipermanent built environment features in the background (e.g., buildings, traffic signs, other built infrastructure), as a visual clue for future field crews to find the tree (see Field Guide section 2.5). Note that, in the Field Guide,

**Table 2.—Tree definitions for various monitoring project types<sup>a</sup>**

Monitoring project type	Tree definition short name	Description
Planting cohort monitoring	Program-specific planted tree	Tree is defined by inclusion in a program's planting list. Only trees planted through that program are monitored, and all are considered trees for inclusion in the study, regardless of size or growth habit (e.g., even species often considered shrubs like crape myrtles [ <i>Laegerstroemia</i> spp.] are included, if on program list).
Multi-age inventory (general)	d.b.h. minimum 1-inch (2.54 cm)	Trees are defined as woody plants with a minimum 1-inch (2.54 cm) diameter at breast height. This method is based on i-Tree Eco and Urban Forest Inventory and Analysis from the USDA Forest Service and has the benefit of being easy for data collectors to reliably determine in the field, but it may exclude some small recently planted trees while including species that are typically considered shrubs.
	Set list of species	Trees are defined by a set list of species to be included or excluded. Species that are not of interest are explicitly not considered "trees" for the study at hand. For example, a repeated inventory could exclude plants with shrubby growth habit (e.g., bamboo clusters, spicebush, buckthorn, privet).
Multi-age inventory (street trees)	Trees between sidewalk and street, and medians	Monitoring is limited to sidewalk cutouts and planting strips site types <b>only</b> if they are located between the sidewalk and the street, and trees planted in street medians. This is a very restrictive definition of street tree (as it excludes sidewalk trees located immediately next to buildings, but includes sidewalk trees immediately next to the curb). This definition may be more consistently applied across field crews over many years of monitoring.
	Trees in sidewalks and medians	Monitoring is limited to the following site types (section 2.4): sidewalk cutout, sidewalk planting strip, and median. (Trees on lawns are not included, even if they are within the right-of-way.) This definition is most relevant in cities where street trees are primarily managed as the trees in sidewalk space. There may be confusion among crews as to whether to record trees located in the sidewalk space, but adjacent to buildings (not the street). By this definition, such trees would be recorded, whereas by the definition in the preceding row, such trees would not be recorded.
	Trees within right-of-way	Monitoring is based on a fixed distance from road center, curb, or edge of road bed (i.e., the right-of-way) as defined by the right-of-way for the local municipality. Any trees within that space are included for monitoring, regardless of whether land use is private versus public land, or site type is front yard versus in sidewalk. This may be the definition most relevant to municipal foresters, but it can be difficult to apply in the field as crews may not know how far the right-of-way extends from the road center for every street. This definition is also most relevant for towns and suburbs that do not have sidewalks. Such towns often consider yard trees near the road to be street trees.

<sup>a</sup> Project supervisors may need to combine definitions, e.g., use both a species list and size cutoff, or use both a street tree definition and size cutoff.

we cover three location protocols in depth. Additional methods and details about pros and cons of all the methods are covered here in the Resource Guide (Table 4 and the remainder of section 2.3).

---

Locating trees with GPS coordinates in the field has shortcomings, particularly when using conventional equipment.

---

Although generating latitude and longitude coordinates for each tree might seem like the ideal information for mapping urban trees, do not rely on these coordinates alone. When coordinates are generated by geocoding street addresses, those coordinates typically fall into the center of a parcel (i.e., not where the tree is really located). When using GPS equipment in the field, readings can be off by several meters if using conventional equipment, although some devices can deliver submeter accuracy with post-processing. Additional issues for generating map coordinates with GPS units are discussed below. Each location method has its own strengths and weaknesses, and the project supervisor must determine which two (or more) methods are best suited for the project.

Note that we do not give detailed guidelines for recording locations with plot-based inventories here. Plots are a special case and randomly generated plot centers can often be difficult to locate. To reliably relocate plot centers, a variety of methods can be employed: reference objects, distance and direction to all trees from plot center, written navigation descriptions to plot center, photos showing a person standing in plot center, and photos taken from plot center facing in each cardinal direction (see Table 3 and section 2.3.9 on reference objects). Permanently marked plot centers and boundaries are ideal (e.g., using flagging and staking) but may not be possible in urban landscapes with numerous private landowners and the potential for public interference with markers. For more information about plot-based location methods, see van Doorn (2014) and i-Tree (2017a).

### **2.3.1. Address and site code method**

Property addresses and site codes are generally used for street trees (see Field Guide section 2.4.1) and it is important for them to be used together as the site code is in relation to the address. For example, address 100 Main Street could have trees at Site Codes 1F and 2F (to indicate two trees in the front of the property), and then 102 Main Street would have site code numbering begin anew with 1F. When there are multiple trees attributed to one address, the use of only an address can result in difficulty distinguishing individual trees from each other. Recording a site code can prevent the ambiguity by identifying the relative position of the tree on the property. Pros and cons of this method are discussed in Table 4.

Depending on project goals, recording address only (without site code) could still be useful in ways unrelated to finding the tree in the field. Addresses can link the tree information to parcel data or U.S. Census Bureau socioeconomic data or support sending mail to the resident to learn about the tree in question through qualitative surveys. In this case, address should not be relied on as a location method to find the tree, but can be used as an additional piece of information for research or management.

**Table 3.—Location methods for urban trees and relevant site types for each method**

Location method	Definition	Relevant site types
Address and site code	Address is the property number and street name for the property on which the tree is located, or the property adjacent to the tree. Site code is a location identification code for the address. This method is most commonly used for street trees. For example, F for front of the address, S for side of the building, M for median. See Field Guide section 2.4.1 for additional details on address and site code protocols for street trees.	Sidewalk cutout, sidewalk planting strip, median, front yard, back yard
Block edge distance	For street trees, this method involves measuring the distance in a straight line from one intersection curb edge to the next intersection curb edge with a range finder, landscaper's tape, surveyor tape, or measuring wheel. See Field Guide section 2.4.2 for protocols for this method.	Sidewalk cutout, sidewalk planting strip, median
Digitizing locations on satellite imagery	A printed or digital satellite image of the study area is marked in the field to show location of the study tree. The location is converted to digital format using a computer program. See Field Guide section 2.4.3 for protocols for this method.	All site types
Identification tag	Identification tag with a code or number, typically affixed to young trees with plastic ties or nailed into large trees.	All site types but particularly useful in natural areas
Global positioning system (GPS) coordinates	Tree's location coordinates (e.g., latitude and longitude). Be sure to note the average accuracy reported by GPS unit (e.g., $\pm 3$ m, $\pm 10$ m, etc.), units, coordinate system, and datum.	All site types
Landscape site map	A site map drawn to scale illustrating trees and other useful landmarks in the landscape. Landscape site maps are typically drawn by a professional arborist or landscape architect, but there are online tools and books to help less experienced participants make landscape maps (Ellis 2015).	All site types, but especially useful for yards and maintained parks
On, from, and to streets	A system for noting the specific block segment on which a tree is located, best suited for street tree inventories on a gridded street system. "On" is the street the tree is actually on, "from" is the street in descending address direction, "to" is the next street in ascending address direction. The side of street could also be recorded (i.e., odd versus even address numbers, north versus south side of the block). See Field Guide section 2.4.1 for details and example.	Sidewalk cutout, sidewalk planting strip, median, front yards
Photos	This method involves taking a photo of the entire tree with enough of a background that will provide context of location, such as an identifiable piece of infrastructure (i.e., house, lamp post, fire hydrant, street corner). New photos should be taken with each field visit to capture changes in the landscape to help future crews find the tree.	All site types
Reference objects	Distance and orientation to objects in the landscape that are unlikely to move for several decades. For example, a reference object for a yard tree could be the northwest corner of the house exterior. The field crews would then measure distance and compass orientation from the tree to that house corner. This method is based on protocols developed for plot-based inventories such as i-Tree Eco. For detailed protocols, see i-Tree (2017a).	Yards; maintained parks

**Table 4.—Pros and cons of the address and site code method**

Pros	Cons
Easy to collect in the field for baseline data.	Provides low-accuracy location information for future monitoring.
Does not require extra equipment.	There can be ambiguity if trees are removed or added over time.
Aligns with street tree inventory methods in many cities.	In cases of building demolition or redevelopment, addresses and site codes may become irrelevant.  Property boundaries and address numbers can occasionally be difficult to discern in the field.

### 2.3.2. Block edge distance method

The block edge distance method is used for street trees and works best on gridded street systems with straight roads. In this method, distance is measured along the curb edge of a street to each tree (see Field Guide section 2.4.2). In addition to the distance measurements, field crews must record street intersections of start and end points and which side of the street they are measuring in relation to the road's centerline (right or left); this information is similar to the on, from, and to streets method (Table 4). The block edge distance method is most efficient when using a measuring wheel but can be done with a long measuring tape. Digital range finders could also be used if the streetscape environment does not have many obstructions (e.g., pedestrian traffic). An efficient way to handle workflow would be to record all the tree distances first and then go back and record other information such as species and d.b.h.

The block edge distance method was developed by TreeKIT (Silva et al. 2013) and has been extensively used in New York City, where tree distances can be translated into map positions using the custom software system specially developed for the city's citizen science street tree census (Crown et al. 2018). The method was also adapted there to enable measurements on curved streets, cul-de-sacs, and other non-gridded streets.

The block edge distance method takes more time to set up compared to the address and site code method, but it provides detailed location information to help future field crews find the same tree without the ambiguities of the address and site code method (Table 5).

In the block edge distance method, all tree measurements are taken in relation to an imaginary starting point that is the projected curb edge. The distance measurement for every tree on that block face is taken in relation to this starting point (e.g., tree at 20 ft [6.1 m] from projected edge, second tree at 40 ft [12.2 m]). However, Silva et al. (2013) originally set up the method to measure the intervals between trees. In their original method,

**Table 5.—Pros and cons of the block edge distance method**

Pros	Cons
Provides highly accurate location information for future monitoring.	Takes time to set up, particularly for the first year (baseline data).
If using a measuring wheel or range finder, it is very easy to measure long distances.	If using a transect tape, inefficient on long blocks because the transect tape may need to be rolled up and laid out again. If using a range finder, pedestrians or other obstructions could interfere with measurements.
Easy to add new trees because measurements to trees are independent of one another.	If there is an error in laying out the transect tape in the beginning, that error will affect all measurements.
	Custom software or time-consuming manual efforts are needed to translate distance measurements into map coordinates.
	Can be difficult to implement for non-gridded street systems (e.g., curving roads, cul-de-sacs) or for grid systems with extremely long block faces.
	Requires equipment that some organizations may not have readily available.

the first measurement is made by recording the distance between the starting point and the center point of the first tree. The measurement on the measuring wheel is then “zeroed out,” and the second measurement is taken by measuring from the center point of the first tree to the center point of the second tree. This procedure is repeated for subsequent trees on the block. The last measurement is taken between the center point of the last tree and the end point, (i.e., projected curb edge of perpendicular streets). An issue with this approach for future remeasurements is that adding new trees into the inventory will change the previous distances between trees. Hence, we recommend the use of the block edge distance method in which distances are recorded to each tree’s center point without resetting the measurement. However, as long as the distance measurements are taken carefully, it should be easy to convert from one approach to the other.

### 2.3.3. Digitizing locations on satellite imagery method

The digitizing locations on satellite imagery method involves referencing a printed satellite image of the study area in the field. These images show overhead outlines of tree canopies, streets, and neighboring buildings. Using these objects as references, the location of the study tree is marked on the image with a pen or marker. Later, the location is converted to digital format on a computer using software such as ArcGIS, Google Maps, or Google Earth. A more direct “high tech” method is to bring a mobile device into the field loaded with a spatial app (e.g., ESRI Collector or Google’s My Maps) that allows dropping points on the satellite image while standing in the field. This cuts down on data processing time in the office.

Using satellite imagery works well in many street tree and lawn situations but may be challenging in wooded natural areas and on densely planted lawns and sidewalks where canopies overlap. When the original location information was based on address and site code, it was possible to prepare a rough estimate of where the tree might be located in order to complete subsequent remeasurements. Online tools such as address to latitude/longitude converters make it possible to plot the approximate property location on a satellite image. In the field, the crew could refine where the tree is located based on the actual canopy location. Note that it is also best to use relatively recent satellite imagery (within the past 1 to 2 years if possible), and that construction, storms, and other events can drastically change the appearance of the landscape image.

For the high-tech method of bringing a mobile device in the field equipped with a GPS receiver, refer to the section on “GPS Coordinates” below (section 2.3.5) for pitfalls related to using GPS receivers. Pros and cons of the digitizing locations on satellite imagery method are discussed in Table 6.

#### 2.3.4. Identification tag method

In rural forest plots, trees are often tagged with unique identification numbers or codes that enable field crews to verify the identity of individual trees (van Doorn 2014). Such tags are often nailed into the trunks of mature trees. The tag can display the tree record identifier. While identification tags are used much more rarely in urban forestry, they have been integrated into a few projects, including a study of programs with high survival in the first several years after planting (Roman et al. 2015). Those tags were loosely tied around a tree branch. Maintenance of identification tags in repeated surveys includes

**Table 6.—Pros and cons of digitizing locations on satellite imagery method**

Pros	Cons
There are open-source satellite images available that make this method potentially inexpensive.	For the low-tech method with paper, it is time consuming to prepare satellite image copies to take into the field and to process data afterwards.
Global positioning system (GPS) accuracy on mobile devices varies, but if crews use high-end devices, this method can provide highly accurate position information for future monitoring and cuts down on processing time.	The high-tech method could require acquisition of potentially cost-prohibitive mobile devices and proprietary software.
Allows for the creation of a map of tree positions useful for analysis, display, and remeasurement.	Requires technical knowledge for processing data after marking trees in the field on satellite images.  Use of mobile devices with GPS has limitations that lead to low position accuracy, especially in “urban canyons” between buildings and under thick, dense canopy.  Requires relatively recent (past 1-2 years) satellite imagery; and imagery can get outdated if the landscape has drastically changed owing to construction or storms.

ensuring the tree is not growing over the tag, that the tag is not girdling the stem, and that the identifier is still readable (e.g., not sunbleached). Crews should be prepared to find a given tree using alternate location methods even if the tag has been removed or damaged. Pros and cons of this method are discussed in Table 7.

### 2.3.5. GPS coordinates method

GPS receiver location accuracy can range from being too coarse to differentiate between two trees, to fine enough that trees planted next to each other are individually identified. Differential global positioning systems (DGPS) provide improved accuracy, from around 15 m (49.2 ft) of ordinary GPS to about 10 cm (3.9 inches) in the best-case scenario. Not all devices are capable of utilizing DGPS, and those that do are generally more expensive and often cost prohibitive for programs with small budgets. Supervisors should weigh tradeoffs between accuracy and cost to reach their program goals. Regardless of which type of device is used, accuracy of the readings (displayed as  $\pm$  meters or feet) should be recorded along with any GPS coordinates. Devices depend on clear line of sight with satellites and therefore encounter “urban canyon” problems characterized by having trouble locating satellites under large dense canopies or in downtown areas where signals may reflect off tall buildings. Downtown areas with tall buildings often have accuracy limitations, such as Manhattan in New York City (Silva et al. 2013). However, for urban areas with shorter buildings, the “urban canyon” issue is not a problem. Pros and cons of the GPS coordinates method are discussed in Table 8.

### 2.3.6. Landscape site map method

Site maps are particularly relevant for neighborhood parks, gardens, and residential yards. In such landscapes, distinguishing between trees in large areas of lawn can be challenging, and planting or inventory records that only report location in general terms (i.e., “10 trees on south side of building”) do

**Table 7.—Pros and cons of the identification tag method**

Pros	Cons
Eliminates ambiguity regarding which tree is in the record.	Requires extra equipment.
Works well for trees in natural areas where interaction with the public (and risk of vandalism) is low.	Tags can be vandalized or otherwise damaged, removed, or lost.
Can work well for trees in parks and along streets as long as tags are periodically adjusted as trees grow.	Requires periodic maintenance action to prevent tree from overgrowing the tag and to prevent the tag from girdling the tree.  Tags nailed into trunks is generally not a viable option for large urban trees that may need to be removed and chipped one day (aluminum tags are safe for chainsaws). But tags around branches can work well for small recently planted trees.

**Table 8.—Pros and cons of the global positioning system (GPS) coordinates method**

Pros	Cons
High-resolution devices provide submeter location accuracy.	Requires extra equipment, and particularly high-cost equipment for submeter accuracy.
Can be used to produce maps for geospatial analysis and visualization of sites.	Not all devices provide the needed level of accuracy.  Receiving a signal in an urban area can be challenging, especially in “urban canyons” and under thick, dense canopy, leading to low position accuracy.

not enable future field crews to locate individual trees. Landscape site maps can be made into two different styles: to-scale and not-to-scale. To-scale site maps have been used in case studies that have shown high survival (Roman et al. 2016). These maps, along with tree tags, allowed for researchers to easily find individual trees over many years of fieldwork. However, these maps are time consuming to construct and thus are rare. For high-profile park, campus, or street projects, there may be opportunities for cities or nonprofits to contract with landscape architects or arborists to develop to-scale site maps used for monitoring or maintenance/inspection cycles. If to-scale maps are unavailable, not-to-scale maps can still be very useful. For example, not-to-scale site maps showing where trees were planted relative to other built features enabled field crews to find the yard trees planted through a shade tree program in Sacramento, CA (Roman et al. 2014a). However, in that study, only one to three program trees were at most houses, and visual clues (e.g., stakes and nursery ties that were distinctive to the program) helped confirm that the crews were standing at the correct tree. To-scale site maps would have prevented some instances of confusion, but the not-to-scale maps were sufficient for most properties. Pros and cons of the site map method are discussed in Table 9.

### 2.3.7. On, from, and to street method

The on, from, and to streets information allows tree records to be grouped at the level of the city block, which can be helpful for both management and field crew logistics. The “on” street refers to the street that the tree is actually

**Table 9.—Pros and cons of the site map method**

Pros	Cons
Site maps provide highly accurate location information for future monitoring.	To-scale site maps are laborious and require specific knowledge and skills.
Limit ambiguity if trees are removed or added over time.	To-scale site maps are time consuming and costly.
May require extra field equipment and software for to-scale maps.	Not-to-scale maps may miss important features if done poorly.

on (which can be different than the parcel address). The “from” street is the street closest to the lowest address, while the “to” street is the next encountered street (going in the direction of ascending addresses). Knowing the on, from, and to streets can help crews return to the location more quickly and allows supervisors to efficiently plan the sampling route for that day. This method can complement the address and site code method (see Field Guide section 2.4.1) and is a required component of the block edge distance method. Pros and cons of this method are discussed in Table 10.

### 2.3.8. Photos as a location method

We strongly encourage that all monitoring projects include a photo of each tree whenever possible, preferably showing the full tree with recognizable built environment or other permanent reference features in the background such as a house or utility pole (see Field Guide section 2.5). This allows field crews to use visual clues in the landscape to ensure that they are standing at the same tree from previous field surveys. New photos should be taken each time the tree is visited to capture changes in the tree and built environment. A photo can serve as a critical backup for other location methods previously described and can help to resolve ambiguities in other records. While we have found photos to be extremely useful for tree location in the most built up parts of the urban forest, such as along streets and in residential yards, individual tree photos may not be relevant in natural areas (however, photos of plot center might be useful). Besides being used for relocation of a tree in subsequent surveys, photos of every tree can assist in catching egregious observation errors when the quality of the data is in question yet there is no possibility of returning to the field (e.g., species or d.b.h. seems impossible for that study area).

Photos for every tree are generally easiest to manage on a large scale when smartphones or other mobile devices are used for fieldwork, so that each photo can be matched to the appropriate tree’s record in the database. When it is not feasible to use mobile data collection, photos can still be taken, but need to be organized to ensure that each photo is linked to a specific tree. For example, a photo could be taken with a field crew member standing

**Table 10.—Pros and cons of on, from, and to streets method**

Pros	Cons
Easy to collect in the field.	Not a stand-alone method; this method should be used in conjunction with either site codes (see section 2.3.1) or block edge distance measurements (see section 2.3.2).
Does not require extra equipment.	
Aligns with street tree inventory method in many cities.	
Allows for efficient planning of daily data collection routes.	

next to the tree, holding a white board with the tree record identifier, or the photo number automatically generated by the camera can be recorded on the data collection sheet. Alternatively, a photo could be taken, first, of a data collection sheet to show the tree record, and then second, of the tree itself. Photos could then be labeled and organized using photo management tools (e.g., Google Photos, Flickr, Tropy). Without that kind of careful organization, finding a photo when it is needed in the field is a difficult task. See Table 11 for a discussion of pros and cons of photos as a location method.

Even if a project supervisor chooses not to take photos of every individual tree, we recommend using photos for the narrower purpose of tree species identification: have field crews take photos of unknown species (see Field Guide section 2.8).

### 2.3.9. Reference objects method

Field crews record the distance and direction from the reference object (an object that is likely to remain in the same location for several decades) to the tree. Examples of reference objects include fire hydrants, overhead utility wire poles, survey markers from the National Geodetic Survey (NGS), and manholes. In i-Tree Eco plots, the reference object information is recorded in relation to plot center, and then tree positions are recorded in relation to plot center as well. Reference objects are often more difficult to find in natural areas as built infrastructure is less likely to exist nearby. For natural area plots, reference objects can be the largest trees on site or the most unusual species. Another approach for natural areas is to install markers such as rebar or whisker strakes at plot center. For more detail about protocols for recording reference objects with i-Tree Eco plots, see i-Tree (2017a).

Poor reference objects include items that are easily moveable, occur frequently and in proximity to each other, or are not easily identifiable owing

**Table 11.—Pros and cons of using photos as a location method**

Pros	Cons
Provides visual clues and backup for future monitoring so that crews can be certain they are recording the correct tree.	Photo management is simplest when using a mobile device with data collection integrated with photos, but such technology may be cost prohibitive.
Is an effective complement to all other location methods described in the Resource Guide.	When taking photos outside of a mobile data collection system, labeling and organizing photos can be very time consuming.
Generally quick and easy to take photos during fieldwork.	
Visual record of changes in tree growth, health, and environmental context, which can be used in presentations or field crew training.	

to size or location. However, even for relatively common infrastructure objects such as lamp posts, there are ways to make it easier for future crews to locate the object. For example, in a survey of i-Tree plots in Philadelphia, a satellite image from Google Maps was printed and brought into the field. Crews used a gold marker to note their three reference objects along with distance and orientation to each object. In addition, the crew took four pictures while standing at plot center facing north, south, east, and west, and a fifth picture of a crew member standing in plot center. When researchers returned to plots to check on data quality, they were able to easily determine plot center. For more discussion of data quality issues in permanent forest plots, including strategies to prevent and respond to those challenges, see van Doorn (2014).

Risks to the stability of reference objects include redevelopment of an urban area or development of a natural area. Such redeveloped or developed areas may have had all trees removed during construction, but sometimes trees are preserved (Ames and Dewald 2003, Briber et al. 2015), and it can be challenging to link these to the original plot and tree data. Table 12 discusses pros and cons of the reference objects method.

## 2.4. Site Type and Land Use

In the Field Guide, we define site type as a description of the area immediately surrounding a tree’s location, and land use as a description of the way the property around or adjacent to the tree is used by humans (see Field Guide sections 2.6 and 2.7). Land use has been more broadly defined in urban planning as “the occupation or use of land or water area for any human activity or any purpose” (The Institute for Local Government 2010; see also Anderson et al. 1976 and Lambin et al. 2006 for additional information about land use definitions and concepts).

Site type categories include sidewalk cutout, sidewalk planting strip, median, and front yard. Land use categories include single family residential (attached and detached), commercial, institutional, and cemetery. The site type and land use variables are related but distinct. For instance, a tree located in a sidewalk cutout (site type) could be adjacent to a property that is

**Table 12.—Pros and cons of the reference objects method**

Pros	Cons
Not dependent on current location of trees.	Finding unique reference objects that seem likely to persist over time may be difficult, particularly in natural areas.
Builds on plot methods for natural areas in forestry ecology.	Redevelopment puts reference objects at risk from being removed or moved causing ambiguity.  Reference objects far from target tree or plot center are difficult to locate.  Requires extra field equipment (e.g., transect tapes or range finders to get distances, and compasses to get orientation).

residential, commercial, or institutional (land use). Similarly, a tree located in a maintained park-like environment (site type) could be within a public park, a college campus, or a cemetery (land use). For additional site type and land use categories for real-world examples, see the Field Guide Table 8, and appendix 1 in this Resource Guide.

There are two main reasons to record site type: (1) each site type has recommended methods of recording tree location, and (2) mortality, growth, and health may vary across site type categories. The site type categories indicate broad information about the area surrounding the planting space (hardscape versus non-hardscape) and controls on tree ingrowth and removals (human-dominated planting versus natural regeneration). We use the term hardscape environment to describe urban trees surrounded by human-constructed hard surfaces, often impervious (e.g., asphalt, concrete) but can also include modern pervious materials (e.g., permeable pavers). Each site type category includes recommended methods for recording location (Table 13). This information is intended to assist project supervisors, who must decide which location method is best for each project. In Table 13, site type is separated according to trees in a hardscape, a maintained landscape (non-hardscape), or a natural area.

While we have not listed the GPS coordinates, photos, and identification tag methods for the site type categories in Table 13, this is because those three methods are appropriate for all site types. However, any of those three methods should be used in conjunction with another complementary method, as described in section 2.3.

**Table 13.—Site type categories with management notes and recommended methods for recording locations. Taking GPS coordinates, using photos, and identification tags apply to all site types.**

Category (code)	Description	Recommended methods for recording location
<b>Trees in hardscape environments</b>		
Tree plantings and removals for these site types are human dominated.		
Sidewalk cutout (SC)	Tree is located in a soil pit in the sidewalk. The cutout can be anywhere in the sidewalk space (e.g., adjacent to the curb, adjacent to a building). This kind of site type is usually intended to fit just one tree.	Address and site code; block edge distance method; satellite image with global positioning system (GPS)
Sidewalk planting strip (SP)	Tree is located in a planting strip next to the sidewalk. This planting strip can be anywhere in the sidewalk space (e.g., between the sidewalk and curb, between the sidewalk and building). Planting strips can fit multiple trees planted in a row (even if only one tree is present). The length of a planting strip is generally at least 10 ft (3.05 m), although there could be exceptions or different sizing descriptions in some cities.	Address and site code; block edge distance method; satellite image with GPS

**Table 13 (continued).—Site type categories with management notes and recommended methods for recording locations. Taking GPS coordinates, using photos, and identification tags apply to all site types.**

Category (code)	Description	Recommended methods for recording location
Median (M)	Tree is located in a planting space in the center of the road between traffic lanes. Includes center medians, traffic circles, and triangular cut-outs.	Address and site code; block edge distance method; satellite image with GPS; landscape site map
Planter box (PB)	Tree is located in a raised planter box.	Address and site code; block edge distance method; satellite image with GPS
Other hardscapes (OH)	Tree is located in a hardscape other than a sidewalk or median, such as cutouts in a park plaza or parking lot.	Satellite image with GPS; distance and orientation to reference objects; landscape site maps
<b>Trees in maintained landscapes, non-hardscape</b> Tree plantings and removals for these site types are human dominated.		
Front yard (FY)	Tree is located in the yard in front of a building (on the street side of the building). This includes side yards (although some studies could record side yards separately). Front yards are typically associated with residential properties but may also be associated with other land use types.	Distance and orientation to reference objects; landscape site maps; satellite image with GPS
Backyard (BY)	Tree is located behind a building. Backyards are typically associated with residential properties but may also be in back of other land use types.	Distance and orientation to reference objects; landscape site maps; satellite image with GPS
Maintained park (MP)	Tree is located in a maintained park or park-like setting, such as a city park, school campus, or cemetery. This category is specifically for trees in lawns and other landscaped areas; park trees located in hardscapes belong in the “other maintained hardscapes” category. Note: maintained park is both a site type and land use.	Distance and orientation to reference objects; landscape site maps
Other maintained landscaped area (OM)	Tree is located in a landscaped area not described by the yard and maintained park categories. Use this category sparingly.	Distance and orientation to reference objects; landscape site maps
<b>Trees in natural areas</b> Tree additions and removals for this site type are generally natural (e.g., natural regeneration and death in place).		
Natural area (NAT)	Tree is located in a natural park, open space area, or vegetated vacant lot that has minimal human intervention. This includes remnant forest patches and other natural or unmaintained areas, regardless of property type (e.g., forest patches on a residential property or institutional property are included here). Natural areas include forests, prairies, woodlands, and other natural or minimally managed habitats. Some project supervisors may choose to separate out the various kinds of locally relevant natural habitats (e.g., forest versus prairie). Note: natural area is both a land use and site type.	Distance and orientation to reference objects

Note that “natural area” and “maintained park” are both site types and land uses. A tree located on one of these site types will not automatically have the same land use, and vice versa. Taking examples from the Field Guide (Table 8), consider a tree in a landscaped lawn of a municipal recreation center. That tree would have “maintained park” for both site type and land use. Now consider a tree located in the landscaped lawn of a hospital complex. That tree would have site type “maintained park” and land use “institutional.” While some urban tree inventory protocols combine the site and property characteristics into one “land use” variable (e.g., i-Tree 2017a), we recommend keeping site type and land use separate because they describe different characteristics—namely, the tree’s immediate growing environment versus how humans use the property.

## 2.5. Longitudinal Database Considerations

---

A database administrator or database engineer can help with ensuring that database design is conducive to monitoring goals.

---

While there are general guidelines for organizing spreadsheets and databases (see section 2.1.18), we discuss here some considerations specific to longitudinal data of urban trees: selecting an appropriate tree record identifier, primary and unique keys, choosing long versus wide data structure, and tracking planting sites and replacement trees.

For more guidance about keys and database structure, see Boyer et al. (2016), which includes a proposed data model for urban tree monitoring, or see more general references about designing relational databases and spreadsheets (e.g., Broman and Woo 2018, Harrington 2009, Hernandez 2013). Project supervisors may also wish to consult with a database administrator or database engineer to ensure that the database design is conducive to monitoring goals, as we barely scratched the surface here regarding database design and administration.

### 2.5.1. Selecting primary and unique keys

In database design, keys allow users to identify, sort, and access information. We discuss two kinds of keys here: unique keys and primary keys.

A unique key (uk), also called a unique constraint, defines uniqueness for the entity that is being stored on the record. For example, in databases of human information, each individual should have a unique identifier such as driver’s license number or employee number. Thus, with urban tree databases, each tree record should have a unique record identifier that remains with that tree (and only that tree) during future monitoring. In the Minimum Data Set, the tree record identifier is an example of a unique key (see Field Guide section 2.3). See Figure 2 for examples of tree record identifiers. A unique key can be derived from a tree tag (when present) or planting records. For planting cohort monitoring projects, the key used to define the uniqueness of a given tree may link with planting records. There may be multiple unique keys defined in a table. For example, a street tree monitored as part of a municipal inventory may have, in addition to a tree record identifier designated by the city arborist, one designated by an outside organization that maintains the trees (e.g., a contractor). It may be valuable to keep track of both tree record

---

In database design, keys allow users to identify, sort, and access information.

---



**Figure 2.**—(A) Tree tag at the University of Pennsylvania in Philadelphia, PA. The lower right corner of the tag has a tree record identifier that reflects a grid cell that corresponds to a campus map and tree number within the grid cell. Photo by J.P. Fristensky, used with permission. (B) Street tree with affixed tag, planted by University City Green, Philadelphia, PA. The tree record identifier here is the identification number used in the nursery. Photo by L.A. Roman, USDA Forest Service. (C) Inventory site map for Casey Trees in Washington, D.C. The tree record identifier is a numerical sequence of trees in this specific area. Image by J.R. Sanders, used with permission.

identifiers to allow for cross-over in databases from both organizations. Another thing to consider is that one or more columns or fields can make up a unique key. A unique key can be constructed in a compound fashion from two or more fields (e.g., the tree number, site number, or year of observation), as long as the combination is unique. As a result, a unique key may span multiple columns. Some users may choose to combine the fields that make up a unique key into one new column and designate that as the unique key. In the examples that follow, we designate unique key spanning multiple columns by highlighting the names in dark grey.

We recommend that the tree record identifier, as the unique key for an individual tree, should only be used for that specific tree, and when a tree is dead or removed, that identifier should be retired to avoid future confusion with a new tree in the same location.

---

A primary key is one of the most critical pieces of information for managing longitudinal data.

---

A primary key is one of the most crucial pieces of information for tracking individual trees through time and is essential for managing longitudinal data. The primary key is a unique value for each record in the database, regardless of what the record represents (Harrington 2009, Hernandez 2013). No two tree records can have the same primary key, and there can be one (and only one) primary key used in a table. Primary keys should not have null values, that is, every record should have a primary key. There can only be one primary key column for a given table, while there can be many unique key columns defined in a table. In practice, a primary key identifies the row of a database and thus should not be repeated within the database or changed. The primary key also serves to join tables within a relational database structure in the easiest, most robust way possible. Relational databases contain multiple tables, and the primary key enables these tables to link together. Primary keys should be something that never (or very rarely) change (Silberschatz et al. 2011). In the examples that follow, primary keys are highlighted in light grey.

A **foreign key** is a column or group of columns in a table that provide a link between data in the same table (in this case a recursive foreign key) or two different tables. A foreign key references the primary key of another table, thereby providing the link between tables. This is particularly useful in long format tables to link to past visits and replacement trees.

---

Unique keys often reflect attributes that are meaningful or natural in the system, while primary keys are generally record numbers that have no deeper meaning outside of the database.

---

While primary and unique keys may sound quite similar, they are distinct. In practice, unique keys are often (although not always) produced using attributes that have some natural meaning in the system, reflecting values or sequences of numbers that are somehow relevant. For example, in databases of human information, driver's license numbers can be unique keys, or in databases of urban tree monitoring to track planting cohorts, the numerical sequence from a nursery tag could be the unique key (and thus the tree record identifier). In contrast, primary keys are often (although not always) produced within the database and have no deeper relevance or meaning outside the database (Larsen 2011). For more reading about database design and keys, see Harrington (2009), Hernandez (2013), Larsen (2011), and Silberschatz et al. (2011).

---

Long and short format data are two options for organizing the structure of a database or spreadsheet that contains longitudinal data.

---

### 2.5.2. Long versus wide data structure

Longitudinal data can be presented in wide or long format (Long 2012).

**Long format data**, also known as stacked data, have the same tree represented across multiple rows, with every observation getting its own row (Table 14). In Table 14, Rec\_id is a number generated by a sequence and represents the primary key. The unique key is composed of Tree\_id and Year. The combination of these two must be unique. In long format, although there is only one tree labeled as Tree\_id #23, the same tree may be repeated in multiple records because more than one measurement was recorded (e.g., Tree\_id #23 was measured in 2010 and then in 2015). Constraints or data validation logic could be used to enforce the unique keys and minimize errors. For example, by instruction from the manager, the database could reject values of Year less than 2010 if there were no data-collecting campaigns prior to 2010.

In contrast, for the **wide format data**, also known as unstacked data, Year is combined with the collected variables (e.g., d.b.h) to generate columns names such as Dbh.cm.2010 and Dbh.cm.2015 (Table 15). Each tree is represented by a single row, with observations across time spanning multiple columns. As in the long data format, the primary key is a number generated by a sequence (Rec\_id), but the unique key is composed of the tree identification number (Tree\_id) and Year in which the observations were made. In this example, Tree\_id happens to uniquely identify the database record (i.e., table row) and could theoretically be designated as the primary key, but we still recommend having separate primary and unique keys. As mentioned in section 2.5.1, generally speaking, primary keys are usually generated within the database to have no real-world relevance or deeper meaning. By creating a primary key whose value has no deeper meaning, if an error were to occur such as an incorrect tree record identifier, the primary key would not be corrupted.

**Table 14.—Example of data presented in long format<sup>a</sup>**

pk	uk		
Rec_id	Tree_id	Year	Dbh.cm
1	23	2010	2.5
2	24	2010	31.2
3	25	2010	3.2
4	23	2015	6.7
5	24	2015	31.5
6	25	2015	3.9

<sup>a</sup> The primary key (pk) is the record id (Rec\_id) and the unique key (uk) is based on a combination of the Tree\_id and Year and therefore spans multiple fields. Separately, Tree\_id and Year are not unique, but their combination is unique. Database managers may choose to combine them into one column.

**Table 15.—Example of data presented in wide format<sup>a</sup>**

pk	uk		
Rec_id	Tree_id	Dbh.cm.2010	Dbh.cm.2015
1	23	2.5	3.5
2	24	31.2	31.5
3	25	3.2	3.9

<sup>a</sup> The primary key (pk) is the record identification number (Rec\_id) and the unique key (uk) is the tree identification number. Trunk diameter measurements were collected in 2010 and 2015.

Among database managers, long format is preferred to wide format for a variety of reasons. Long format is often required for advanced analyses and graphing and is well suited for vectorized programming languages like R (R Core Team 2017). If there are many variables or many years of data, tabular data storage can become unwieldy, especially in wide format. When a large amount of data is collected and recorded, it can be advantageous to move from simple tabular software, like Microsoft® Excel, to a more robust relational database system. A long format is also more robust to the issue of adding or removing variables in the data collection protocol, as sometimes happens in the evolution of a long-term monitoring project. Note that it is possible to convert from wide to long format and vice versa after the data have been collected, as long as the primary key has been retained for all observations, highlighting the importance of the primary key being kept separate from the unique key. One can use a long format for the master data set and convert to wide format for data collection or analysis if that is needed.

As emphasized in the beginning of section 2.5, urban forestry professionals who are unfamiliar with these kinds of database issues may want to consult a database expert to ensure that their monitoring data sets are structured in the most useful manner for the intended analyses.

### **2.5.3. Tracking planting sites and replacement trees**

Some projects may choose to keep track of both trees and planting sites, especially for street tree monitoring or other hardscapes for which planting sites remain relatively fixed in space. Planting sites with trees that have been removed either remain vacant or are replaced with a new tree. A planting site can be occupied by different trees over the years. Planting site vacancies and replacement rates may be of interest to managers and researchers as they have implications for stocking levels and population trajectories.

Tables 16 and 17 illustrate how to track planting sites and replacement trees in wide and long format data. In both examples, Site\_id refers to a specific planting site, whereas Tree\_id refers to a specific tree.

**Table 16.—A table of data in wide format shows how to track planting sites and replacement trees<sup>a</sup>**

pk	uk						
Rec_id	Site_id	Tree_id.2010	Dbh.cm.2010	Tree_id.2015	Dbh.cm.2015	New_tree.2015	Replaced.2015
1	1	23	2.5	59	2.2	Yes	Yes
2	2	24	31.2	24	31.5	No	No
3	3	25	3.2	25	3.9	No	No
4	4	NA	NA	60	2.6	Yes	No

<sup>a</sup> Rec\_id represents the primary key while the unique key spans multiple columns and is composed of Site\_id and Tree\_id.2010. Variable names for observations and measurements (Tree\_id, Species, and Dbh.cm) are combined with Year to reflect when the observations were made.

**Table 17.—A table of data in long format show how to track planting sites and replacement trees<sup>a</sup>**

pk	uk					
Rec_id	Site_id	Tree_id	Year	Dbh.cm	New_tree	Replaced
1	1	23	2010	2.5	No	No
2	2	24	2010	31.2	No	No
3	3	25	2010	3.2	No	No
4	4	NA	2010	NA	NA	NA
5	1	59	2015	2.2	Yes	Yes
6	2	24	2015	31.5	No	No
7	3	25	2015	3.9	No	No
8	4	60	2015	2.6	Yes	No

<sup>a</sup> Rec\_id represents the primary key while the unique key spans multiple columns and is composed of Site\_id, Tree\_id, and Year.

In the wide data format (Table 16), Tree\_id is recorded in separate columns for each time it was observed (e.g., Tree\_id.2010 refers to trees recorded in 2010). If a specific tree is new to the site, we designate “yes” in the column New\_tree.2015, as with Rec\_id #1 and Rec\_id #4. Trees can be designated as new whether they occupy a previously filled or previously empty site. If the distinction between site occupancy is needed, a new column such as Replaced.2015 (Table 16) can provide additional specificity, as in the next example. Similarly, if plantings in previously vacant planting sites are of interest, a new column can be added to collect that information.

The first record (Rec\_id #1) in Table 16 is an example of a site in which a tree was replaced after the first visit. It was originally Tree\_id #23 in 2010 with a 2.5 cm d.b.h. tree but was replaced by a 2.2 cm d.b.h. tree with Tree\_id #59. Because the tree was new to the site, it was added to the New\_tree.2015 column. For clarity, we added another column (Replaced.2015) to designate that Tree\_id #59 replaced a tree that had occupied the site in the previous measurement; this allows for easy querying to find all the replacement trees if calculating the replacement rate is of interest.

Table 16 also illustrates the differentiation between sites and trees. The fourth record (Rec\_id #4) represents a site that did not have a tree in 2010 (i.e., vacant site). Note that in this context, vacant site refers specifically to a planting site that is unoccupied, i.e., does not have a tree. In the street tree context, a vacant site is sometimes called an empty tree pit. Because Site\_id was a variable in the table, the crew could record that Site\_id #4 was visited but there was no tree present. Following the best practices laid out by Broman and Woo (2018), rather than leaving these cells blank, we use “NA” to show the cells were not left blank by accident. When the crew returned in 2015, a tree was observed at that site (Tree\_id.2015 #60) and measured (2.6 cm d.b.h.). Again, for clarity and easy querying, we added a column (New\_tree.2015) to designate that a tree was newly observed as of 2015. Without New\_tree.2015, it would be unclear from Rec\_id #4 whether the site was visited in 2010 and no tree was found or whether the site had never been visited. One could also add a column to designate empty sites in any given year (e.g., Vacant\_site.2010, Vacant\_site.2015), if calculating the percentage of occupied sites (or stocking level) is of interest. A drawback of the wide data format is that this procedure of keeping track of replacement or new trees is prone to errors as the database grows with successive monitoring years.

The same data set in long format will look different, but the distinction between site and tree remain the same (Table 17). Instead of columns being made up of variables collected in a particular year (e.g., Dbh.cm.2010, Dbh.cm.2015), columns containing the variable (e.g., Dbh.cm), and the years in which the variable was collected make up different rows.

Data may also be organized in a relational database. Splitting data into a number of related tables provides some advantages. Data are only stored once, so changes do not require multiple record changes. Relational databases provide additional flexibility for future additions, even if no other records are using the additional records. For example, a table with planting site information can include all possible planting sites even if there are no corresponding trees in a tree table. In Table 18, the data presented in long format consists of two subtables in a relational database: the parent table (Site table) describes planting site information, and the child table (Tree table) describes tree information. Given that planting site and tree information are in separate tables, different trees can occupy the site over the years. Rec\_id is the primary key in each sub-table. In Site table, the unique

**Table 18.—Tables of data in long format show how to track planting sites and replacement trees in a relational database<sup>a</sup>****Site table**

pk	uk			
Rec_id	Site_id	Visit_number	Year	Soil_depth.cm
10	1	1	2010	50
11	2	1	2010	70
12	3	1	2010	100
13	1	2	2015	45
14	2	2	2015	30
15	3	2	2015	100
16	4	1	2015	40

**Tree table**

pk	uk		fk		
Rec_id	Site_table_rec_id <sup>a</sup>	Tree_id	New_tree	Replaced_tree_rec_id	Dbh.cm
20	10	23	No	NA	2.5
21	11	24	No	NA	31.2
22	12	25	No	NA	3.2
23	13	59	Yes	20	2.2
24	14	24	No	NA	33.0
25	15	25	No	NA	3.9
26	16	60	Yes	NA	2.6

<sup>a</sup> Site\_table\_rec\_id is also a foreign key (fk). In both Site table and Tree table, the primary key (pk) is the record id (Rec\_id). In Site table, the unique key (uk) is the combination of Site\_id and Visit\_number. Similarly, in Tree table, the uk is the combination of Site\_table\_rec\_id and Tree\_id. The Tree table is linked to the Site table by way of the foreign key (Site\_table\_rec\_id). Site\_table\_rec\_id references the primary key in Site table (Rec\_id, not Site\_id).

key is composed of Site\_id and Visit\_number. Site\_id and Visit\_number are part of what makes each record unique. Site table and Tree table are linked by a foreign key (Site\_table\_rec\_id in Tree table). Site\_table\_rec\_id references the primary key in Site table (Rec\_id, not Site\_id). In the Tree table, the unique key is composed of Site\_table\_rec\_id and Tree\_id.

Record #12 in Site table (Table 18) shows that site #3 was sampled in 2010. Because Site\_table\_rec\_id provides the link from Tree table to Site table, we can look for Site\_table\_rec\_id #12 to see if any trees were recorded at site #3. Indeed, record #22 shows that tree #25 was measured. To look up the soil depth for tree #25, we could follow the Site\_table\_rec\_id link back to record #12 in Site table to see that the soil depth was 100 cm. Record #15 in Site table shows that in 2015, site #3 was once again sampled. Tree #25 was still present so it was measured (Rec\_id #25).

Foreign keys provide the link between tables. In Tree table, Site\_table\_rec\_id is a foreign key to the parent Site table record. It points to the primary key in Site table. For example, Rec\_id #20 refers to Site\_id #1 because the foreign key (Site\_table\_rec\_id) points to Site table's Rec\_id #10.

A foreign key also presents a way to track replacement trees. For example, Tree table's Rec\_id #23 shows an entry for Replaced\_tree\_rec\_id (#20). Replaced\_tree\_rec\_id is a foreign key that links record #23 (which holds information for tree #59) to record #20 (which holds information for tree #23). In other words, in 2010, the crew sampled site #1 and measured a tree labelled Tree\_id #23, but in 2015 they encountered a different tree in its place, determined it was a replacement tree, and labelled it Tree\_id #59. The field Replaced\_tree\_rec\_id also helps differentiate between trees planted in vacant sites and trees replacing other trees (i.e., replacements). For example, Tree table's record #26 shows that Tree\_id #60 is a newly planted tree in a new location (i.e., not a replacement tree) as it only has information for year 2015, it is listed in the New\_tree column, and column Replaced\_tree\_id remains empty.

## 2.6. Data Collection System

Field-based urban tree monitoring data can be collected with either mobile devices or paper. There are pros and cons of each approach. Despite technological advances in conducting tree inventories with mobile devices, many monitoring projects may continue to use paper, owing to resource limitations in acquiring hardware and software, or for citizen science projects, paper data collection may make participation more widely accessible to all residents. However, drawbacks to paper data collection include the possibility for transcription errors during data collection and the need to regularly copy or scan original data sheets as backup (Table 19). A template data collection sheet for the Minimum Data Set is provided in the Field Guide appendix 2.

**Table 19.—Pros and cons of using paper data collection**

Pros	Cons
Low cost, low-tech method.	Backing up data is more time consuming (e.g., copying or scanning data sheets versus downloading an electronic file).
If pursuing a citizen science approach, paper data sheets may be more comfortable for some volunteers (e.g., older residents or those without smart phones).	Data entry into a computer is time consuming and introduces a possibility of transcription errors.
Data entry into a computer could provide an opportunity for a transcriber to review all the data and flag unusual entries.	No way to restrict variables to prevent out-of-bounds errors.
Provides a hard copy backup of data when computers fail.	
Flexibility with work flow for field crews (i.e., crews using mobile systems often have to enter one tree at a time, but with paper, crews could measure and record all location information, then all d.b.h. measurements, or other options to maximize flow).	

A comprehensive assessment of software packages that might be useful for urban tree monitoring, including many mobile data collection packages, is given in Boyer et al. (2016). However, none of the software systems evaluated in that report were perfectly suited out of the box to longitudinal data collection and repeated monitoring. Since release of that report, two software systems (OpenTreeMap by Azavea and the Urban Forest Cloud by Plan-It Geo) have begun offering options for monitoring planting cohorts. When selecting what software to use for a monitoring project, we recommend carefully evaluating software requirements and intended users (with Boyer et al. 2016 as a guide for both those issues). Existing software options evaluated in that report include proprietary urban forestry software, proprietary nonforestry specific software, and free and open source software. Some proprietary urban forestry software can be customized for monitoring, but with greater customization comes greater financial cost.

Among the various requirements of a monitoring software system, we highlight two issues: location data and longitudinal data management. Existing software packages may not be structured to record location data using the methods described in section 2.3 or may not be structured to enable recording of at least two forms of location, which we recommended as a way to have backup information. We also strongly encourage photos of individual trees for most urban forest monitoring studies. However, having photos linked to individual tree records and the ability to mass export photos is not a feature in all the software packages evaluated in Boyer et al. (2016). Additionally, available software packages for urban tree inventories may not be conducive to longitudinal data analysis. When proprietary urban forestry software is designed to manage tasks for maintenance crews, new data about a tree may literally replace old data for the user's view of the information, without retaining the longitudinal records in a manner that allows calculation of mortality and growth or tracking of replacement and new plantings. Such data may sometimes still exist in the software database, but it may be cumbersome for managers to access and connect records across time. Nevertheless, mobile data collection does have advantages, including eliminating the step of transcribing data sheets and potentially enabling photos to be linked to tree records. We summarize pros and cons of using mobile data collection software in Table 20.

## 2.7. Research-Practice Partnerships

To carry out productive urban tree monitoring studies, it helps to have strong partnerships between researchers and practitioners. Both parties bring essential skills and experience to the table. Researchers know how to design study samples, analyze data with rigorous statistics, and match those issues with clear research objectives, while urban forestry professionals have in-depth experience managing their trees and can generate innovative questions and insights to interpret results. Forging partnerships between researchers and practitioners can also potentially lead to outputs that are actionable for urban forest managers, such as internal program reports or presentations

---

Collaborative research-practice partnerships can strengthen urban tree monitoring studies.

---

**Table 20.—Pros and cons using mobile data collection software**

Pros	Cons
May allow field crews to view tree locations on a map or satellite image, if the device has a data plan or ability to download maps and tree location data exists.	Software, mobile devices, and data plan access may be cost prohibitive.
Data entry options can be restricted for each variable to prevent out-of-bounds errors for continuous variables and provide a limited set of options for categorical variables (e.g., d.b.h. cannot exceed 100, species and mortality status are selected from drop-down menus).	If pursuing a citizen science approach, paper data sheets may be more comfortable for some volunteers. Glare on the screen of a mobile device can also be challenging in some weather conditions.
May enable photos to be associated with individual tree records in the database.	Mobile device may need to be charged nightly and a spare source of power should be taken into the field. In addition, data should be downloaded frequently to prevent data losses.
	Can require expensive data plans for every device to record map coordinates and upload data.
	Mass export options of data and files (e.g., photos) may not be available.

to local professionals, in addition to peer-reviewed journal articles. For a discussion of various forms of knowledge co-production at the research-practice interface in urban forestry, see Campbell et al. (2016). Examples of research-practice collaborations for urban forest monitoring include analysis of survival and growth in planting initiatives from San Francisco, CA (Martin et al. 2016), towns across Florida (Koeser et al. 2014), Indianapolis, IN (Vogt et al. 2015a), Sacramento, CA (Ko et al. 2015a, Roman et al. 2014a), and East Palo Alto, CA, and Philadelphia, PA (Roman et al. 2015). These studies have advanced the basic science of urban tree survival and growth while also producing useful data for local managers to apply to their programs.

## 3. Managing Fieldwork

### 3.1. Tips for Training Field Crews

---

Training and actively supervising field crews promotes data quality.

---

Once the organizers of a monitoring project have solidified project goals, decided upon sampling and data collection strategies, and hired field crews, it is time to train the crews. Based on our collective experience managing hundreds of field crews, the more time spent on training and technical assistance during the field season, the more consistent the data will likely be, and with fewer data quality issues. Designing and following a training protocol will help guide these efforts. If training time is limited (i.e., a day or less is available), focus on the more challenging parts such as trunk diameter and species. See appendix 4 for sample training agendas and activities.

#### 3.1.1. Indoor training

Part of the training can occur indoors. We recommend emphasizing the following items with indoor training:

- **Present an overview of the Field Guide with a focus on the more difficult sections.** During training, supervisors can present an overview of the guide and go more in depth on the more difficult sections. Do not assume that all crew members have read the entire Field Guide ahead of time. Allocating time to go over a few subsections (perhaps even reading some aloud together) can ensure that all crew members have reviewed key information.
- **Introduce all equipment.** Trainees should become familiar with all the equipment they will be using in the field (i.e., what each item is used for, what it is called, what units to use, what are possible pitfalls) and any written material they will need to take with them into the field (e.g., field guides or cheat sheets). The crews should practice using this equipment outdoors but should first be introduced to their tools indoors. For example, crews could practice measuring diameters of each other's wrists in the classroom before practicing d.b.h. measurements on trees outside. The supervisor can ensure that everybody is reading the diameter tape (generally referred to as **d-tape**) correctly (see sections 3.3 and appendix 4 activity "D-tapes and Wrists"). This specialized forester's measuring tape is the best piece of equipment for measuring trunks 1 inch (2.54 cm) or larger. For electronic equipment, trainees should also learn how to calibrate electronic equipment and follow a protocol of how frequently to calibrate. For example, if measuring tree height (see the Tree Data Set, section 7), hypsometers should be calibrated daily because they depend on ambient temperature.

---

Safety discussions are an important part of field crew training.

---

- **Practice activities to promote active learning.** Such activities are meant to preview the work that crews will do in the field. For example, trainees can do practice worksheets to learn how to record location with address and site code, practice using measuring wheels to record the block edge distance method, or practice measuring d.b.h. using each other's wrists. The supervisor can also train on species identification indoors using images of trees paired with leaf samples, to be complemented by practicing species identification outside later. Example activities ("D-tapes and Wrists" and "Address and Site Code Map Quiz") are provided in appendix 4.
- **Discuss safety.** The indoor session is also a good time to discuss safety concerns and safety-related protocols. These protocols may differ by organization and city but should generally include safe practices for drivers and pedestrians, any locally specific threats (e.g., tick-borne illnesses, poisonous plants that could cause rashes), and how to report an incident. Have the trainees sign appropriate liability waivers or insurance coverage forms. Safety equipment should be customized for the area in which the crew is working. Brightly colored safety vests provide visibility for traffic and can make crews look more official for pedestrians and residents. Hard hats are recommended if there is a risk of falling materials. First aid kits can be customized to include remedies for situations such as bee stings and poison ivy. Project supervisors should continue to discuss safety with field crews throughout the field season. Supervisors should also stress that sexual harassment and bullying are not tolerated. Many resources with safety guidelines are available online, and include the following topics: heat illness, stress, and safety (CDCP NIOSH, n.d. a; NWCG, n.d.; NWS, n.d.), driving hazards (CDCP NIOSH, n.d. b), and personal protective equipment (USDL OSHA, n.d.).
- **Discuss how to interact with the public.** Urban forestry fieldwork often involves interactions with pedestrians and residents. In the case of planting cohort monitoring, fieldwork may also involve interactions with residents who received trees. Supervisors should coach field crews regarding what to say during these interactions, such as short explanations of the study goals and who the public can contact for more information. Such training for field crews is not only important to maintain good public relations for the organization(s) that the crews represent, but can also help to promote data quality. The workflow of tree measurements can be disrupted by conversations with residents and pedestrians so it is important to have a strategy ahead of time to address these interactions politely and efficiently. A script for field crews to follow during these conversations, or a handout for them to distribute, could be helpful. Some residents may want advice about tree planting, maintenance, and removal, so crews should come prepared with contact information or brochures for relevant local programs. Dyson et al. (2019) provide additional tips on conducting research on private property.

---

Field crew training should include explicit discussions about sources of error and how to respond to any errors that are discovered.

---

- **Discuss sources of error.** We recommend having an explicit discussion with the trainees about potential sources of error. The purpose of this discussion is to encourage field crews to imagine the ways in which they might make mistakes, explain how to reduce those mistakes, and discuss how to respond to errors if they are discovered after the fact. An example activity on this topic is provided in appendix 4 (“Sources of Error”).

### 3.1.2. Outdoor training

An outdoor training session would include putting into practice what has been learned. This is a good time to make sure that crews are comfortable with the equipment and are using it properly. We recommend including the following items in the outdoor training session:

- **Everyone should practice making observations, taking measurements, and recording data.** All members should practice measuring the same set of trees so that results can be compared and differences can be discussed. Often times a trainee does not realize the assumptions that are leading to systematic errors, so crew members may not anticipate where they need assistance. Crew members should rotate roles of making observations, taking measurements, and recording data. Make sure there is consistency in observations across individuals and teams. Data do not necessarily need to be identical across every trainee but should be within reasonable bounds for the study goals (see 2.1.13). For example, Roman et al. (2017) proposed that d.b.h. measurements within  $\pm 1$  inch (2.54 cm) of expert measurements are appropriate for most urban forest management applications, whereas a tolerance of  $\pm 0.1$  inch (0.254 cm) is appropriate for most research applications. In that study, citizen scientists recorded d.b.h. values within  $\pm 1$  inch (2.54 cm) of experts for 93.3 percent of single-stem trees, and within  $\pm 0.1$  inch (0.254 cm) of experts for 54.4 percent. With brief training and a little outdoor practice, most intern or volunteer crews should be at least that consistent, if not better. If the data from this training session are recorded and given to the supervisor, then they could be used to make quick graphs illustrating the level of agreement across crews (e.g., for trunk diameter and crown vigor). Such an exercise can demonstrate areas where trainees need more help as well as serve as a learning experience about data quality.
- **Practice data collection call-and-response.** We recommend that data recorders should get into the habit of reading back what the measurer calls out before writing it down (or entering into a mobile device). This is especially important when there are loud city sounds or distracting pedestrians. For example, a person measuring a tree would call out “d.b.h is 3.5 inches at 4.3 feet” and the recorder would respond “I heard 3.5 inches at 4.3 feet.” This gives the measurer the opportunity to correct the recorder if needed. This process also forces the measurer to slow down and keep the same pace as the recorder (see description of potential division of labor in section 3.2).

---

To maintain data integrity, data recorders should read back what the measurer calls out before writing it down.

---

---

Strategies for species identification training will depend on data quality needs as well as prior expertise of field crews.

---

- Species identification practice.** Beyond practicing the entire data collection protocol on a few trees, additional time could be spent practicing species identification. The supervisor could go for a walk with the crew in a neighborhood or park that has many species they are likely to encounter during the field season. When coming upon a species that has been reviewed, ask crew to identify it. How do they know? What characteristics help them identify it? Reinforce features of the tree species' leaves, bark, or fruit that make it stand out or that distinguish it from other similar-looking species. Bring any portable tree identification resources and practice using them in the field (see appendix 2 for a list of urban tree species identification resources). Make sure that crews know what to do when they encounter unknown species, including consulting with online or print resources, asking the supervisor for help, or recording the tree as "unknown species" (see Field Guide section 2.8). The time needed on species identification will depend upon the crews' level of prior training as well as how important highly accurate species data are for the project. If genus-level identification is sufficient, then less time needs to be spent with this training. If species-level identification is paramount, then more time needs to be spent with this training and the supervisor should consider hiring expert crews or using photos for species validation (see Field Guide section 2.8 and Roman et al. 2017). For planting cohort monitoring studies, crews do not need to know all possible species in an area, but rather, only the set of species planted for that cohort; such crews are using prepopulated species data from planting records to confirm that they are at the right tree, rather than identifying a given species "from scratch."
- Practice with the intended data collection platform.** Whether using paper data sheets or a mobile device, have crews practice their data collection with the actual system they will be using for the entire field season. Check their entries to make sure that they are recording data appropriately. Learn about the crew members' strengths with data entry, so that if one person has neater handwriting or is more adept at using a mobile app, that person may primarily assume the relevant role (see section 3.2 about field crew roles).
- Allow ample time for questions.** Include sufficient time for crews to ask questions while practicing data collection in the field. Do not rush their practice time. Ask the trainees which variables they found most difficult to collect and which they found easiest; then practice or demonstrate again as needed.
- Provide technical assistance for the first data collection day.** Supervisors, crew leaders, or trainers should accompany crews on their first outing. Such supervisory staff should be present to quickly answer technical questions and give guidance, not to collect data for the group. This supervised data collection is especially important for inexperienced field crews (e.g., citizen scientists, interns with little prior fieldwork),

but also matters for more seasoned field crews to ensure that they are following the specific protocols designed for a particular monitoring project. For monitoring projects that are particularly focused on high data quality, field crews could be accompanied by supervisors or trainers for their first full week of data collection during a season of fieldwork.

### 3.2. Tips for Managing and Supporting Field Crews

Effective management of field crews is a key role of the project supervisor. Investing time and resources into higher level planning can make crews more efficient with their time in the field, and, we suspect, also leads to higher data quality. We recommend considering the following items:

- **Seasonality of data collection.** Consider deciduous trees and the timing of spring leaf out and fall leaf changes, which can affect determination of mortality status and crown vigor. If data are collected too early in the year, the leaves might not have appeared in full yet, whereas collecting data too late may result in leaves that are already browning. In such circumstances, crews may not be able to distinguish seasonality versus loss of vigor. If the study intends to measure growth and health changes between years, then repeated measures should be conducted at roughly the same time of year, and typically after trees have stopped growing for the year. Conservative estimates of how long field surveys will take are preferable as overflow into another season might not be appropriate. Plan ahead by estimating the length of fieldwork based on time per tree and transportation to ensure that field surveys can be accomplished within the desired season (see section 2.1.5).
- **Plan the day-to-day route.** Carefully plan transportation routes each day for fieldwork that is scattered across a city. This will make the days much more efficient and allow crews to count more trees per day (see section 2.1.5). Different routes will be required depending on the mode of transportation (e.g., car, public transit, bicycles). Transportation routes should include the optimal sequence of trees or plots to visit as well as directions between sites. Field crews or the project supervisor should allocate office time to plan their transportation routes (e.g., using Google Maps). For cities with particularly bad traffic problems, consider scheduling fieldwork to begin before morning rush hour, or using bicycles or public transit rather than cars. For residential yard trees, consider evening or weekend fieldwork when residents are more likely to be home and allow access (and adjust expected travel times accordingly).
- **Include frequency of data transfer and backups in the field crew management protocol.** If recording data on paper in the field, enter data into computer daily (ideally) or at a minimum, weekly. With frequent data entry, any discrepancy or confusion can be addressed while the site is clear in the crew's memory, or revisiting the site may be possible. When sheets are complete, leave them in a safe place in the office, instead of having the crew continue to take them out into the field.

---

Careful planning for field crew transportation routes can lead to more effective data collection.

---

Make scans as a backup. Daily backups are preferred for electronic data recording. Rename the file to the day it was downloaded in case future files are corrupted and there is a need to revert to the last working data file. If the recorded data are automatically uploaded into a cloud system, the supervisor should ensure that the entered data are complete.

- **Have data recorder check against previous measurements.** If trees are being remeasured, it is helpful for the recorder to have the previous measurements to check when there is confusion about a tree and to identify “blunders” (van Doorn 2014) while still in the field where they can be fixed (see “Create a quality control protocol” below). This will require having prior measurements available as a reference either on paper or electronically. For example, imagine a scenario where a crew is measuring a tree that was measured 5 years previously. The recorder should know the location and species information and should also have the tree photo (if available) to help find the same individual tree. The person measuring the tree should not know all of the previous data, such as trunk diameter and crown vigor, so that there is no bias in the current measurement. However, to ensure that d.b.h. growth is properly measured at the exact same spot on the trunk, the recorder will need to tell the measurer what height was used with the previous data.
- **Have regular team meetings with the field crews.** The supervisor and field crew members should meet regularly to discuss progress and address any challenges that have arisen. Topics to discuss include difficulties with equipment, resolving any unknown species, sharing stories of interactions with the public, and reiterating safety protocols. Ideally, these team meetings should occur weekly and could be paired with other office work for the crews, such as scanning data sheets and planning transportation routes for the coming week.
- **Optimize crew sizes based on available people and data needs.** Although it might seem that having more crew members is better, at some point a large crew size is inefficient. The main limiting factor is the speed of the recorder, as too many people taking measurements and relaying data can result in mistakes or miscommunication.
  - **A two-person crew.** Typically, the minimum comfortable crew unit is one recorder and one measurer. In addition to the efficiency of two pairs of hands for carrying both the recording device and measurement tools, this crew size provides a chance for unbiased quality control checking. A two-person crew is also beneficial for safety reasons in case of an emergency or injury. In addition, crown assessments (e.g., crown vigor) benefit from having two pairs of eyes inspect and average the results, and trunk diameter benefits from careful measurements of both trunk diameter and height to the measurement point, requiring two sets of hands. Having a small crew may mean that the recorder waits for data to enter,

---

Regular meetings with the field crews and supervisor are important to manage logistics, discuss challenges, resolve data issues, and reiterate safety procedures.

---

although it is possible for the recorder to take on other tasks, such as photographing the tree. The recorder should also implement quality control protocols in the field, asking for remeasurements when needed (see bullet point below in this section for tips on establishing a quality control protocol).

- **A three-person crew.** The advantage of having an additional crew member is that the recorder is kept busy with the flow of data. This also means that the recorder has more data to consider rapidly and should be very organized and prepared to set the timing of data entry at a productive yet unrushed pace. It helps to have the data collectors try on the role of recording so that they know at which pace to call out data and in which order (e.g., mortality status first, then crown vigor, then trunk diameter, or whatever flow seems to work best for that project). If possible, data collectors should queue up all the data for one tree and call out the information while having undivided attention from the recorder. Then the recorder can direct his/her attention on the next tree. Alternatively, the third person can take on tasks that require minimal interaction with the recorder, such as photographing the tree, and providing an extra hand with d.b.h. The third person could also be primarily in charge of talking to residents, allowing the other two individuals to remain focused on the data. A third person can also be particularly helpful if variables from the supplemental data sets are collected (sections 7, 8, 9, 10).
- **A four (or more)-person crew.** There is such a thing as too big of a crew. In some cases, it is better to split up into multiple groups and inventory plots/trees in parallel. However, depending on individual abilities and interests, it could still be beneficial to have a four-person crew. Four crew members could drive together to a neighborhood and have pre-assigned plots or street segments near each other, so that they are operating in parallel but in proximity. Four people may also be appropriate if monitoring is paired with other tree maintenance work in the field. With planting cohort monitoring, the local planting organization may wish to have field crews discuss tree stewardship with residents or do basic tree care in conjunction with the data collection (Roman et al. 2018b). In a four-person crew, two individuals could complete data collection and recording while two others could focus on tree care and resident interactions.
- **Create a quality control protocol.** Quality control is a system of maintaining a standard of data quality by testing a sample of the data collected against the specifications. The purpose of a quality control protocol is to provide a set of tangible steps that help reduce nonrandom errors. There are different time increments throughout the data collection process that can serve as data quality checks. Many of the points discussed below are based on the experience of scientists at Hubbard Brook Experimental Forest (in the White Mountains of New

Hampshire) who have collected and managed tree data for decades. While these suggestions come from monitoring projects conducted by research scientists and graduate students, with data intended for scholarly analysis and scientific publications, urban foresters at municipalities and nonprofits may also find these suggestions valuable.

- **Daily:** Before leaving a street, plot, or other sampling area, a crew member should check that all fields on the data sheet have been filled in and that all trees have been recorded. For example, when recording all street trees on a city block, crews could go back and count how many trees were on that block, as a way of double-checking if they missed or double-counted any trees (Roman et al. 2017). A similar strategy can be applied to plots.
- **Weekly:** The supervisor should allocate time for addressing notes for supervisory review (see Field Guide section 2.13) in the collected data, either daily, weekly, or biweekly. Do not leave this task to the end of the field season. It is more efficient to review issues when the data are fresh in the crew's minds.
- **Seasonally:** The supervisor should conduct checks at the beginning of the field season, preferably during the first week to catch any major errors. For example, crews might have specific species misidentification problems or make repeated mistakes with the equipment (e.g., reading d-tape backwards; see Field Guide section 2.12.2). Catching these mistakes early allows crews to improve their work and may provide time to re-do trees or plots with inaccurate data. Check on crews periodically throughout the field season to ensure that they are continuing to collect high-quality data. FIA and UFIA programs provide protocols (USDA FS 2016, 2017) on data quality checks, with expert and highly experienced crews checking on data collected by seasonal professional foresters. However, it is important to keep in mind that these are professional field crews with levels of resources that may be beyond what urban forestry programs with limited resources are able to provide.
- **Data value thresholds:** The supervisor should set, before the project begins, acceptability thresholds for what is an acceptable level of change from previous measurements that would distinguish a biologically driven change versus a "blunder" (van Doorn 2014). For quantitative measures such as d.b.h., this can be a percentage or amount above or below d.b.h. (see section 2.1.13). If a measurement is read outside of that threshold, the recorder would ask for a repeated measure, without revealing the issue. The next measurement would be recorded, regardless of whether it is higher or lower than the first measurement, to not introduce bias. The same strategy can be applied to qualitative evaluations such as crown vigor. The supervisor can set thresholds such as a two-class vigor change from

---

Quality control is a system of maintaining a standard of data quality by testing a sample of the data collected against the specifications.

---

previous data. For example, at Hubbard Brook Experimental Forest, the protocol calls for the recorder to look at the vigor rating recorded in the previous survey to make sure that current tree vigor is not mistakenly recorded as alive when previously recorded as dead (see discussion of “zombie trees,” section 2.1.16). In addition, any two-step crown vigor class change, in any direction, requires a repeat evaluation as sometimes the wrong tree crown was inspected.

- **Allocate time for active management of the project.** Supervising field crews is not a side job! Program managers taking on crew supervision responsibilities should be aware that work begins 2 to 4 weeks before the crews start and ends 2 to 4 weeks after the crews finish (if not more!) owing to the time it takes to prepare and organize the field season. To ensure that field crews can make the most productive use of their time and collect ample data, the project supervisor needs to have a clear plan for the entire season. This includes preparations for training activities. During the field season, the supervisor will need to spend considerable time communicating with the crew and responding to questions, addressing notes for supervisory review, and having regular check-in meetings with the crew. Hiring a temporary summer field team supervisor can allow the primary program staff to continue with their regular work. For example, graduate students with years of field experience could be the temporary supervisor while undergraduates are the field crew interns. To balance the financial costs, it may be necessary to hire fewer field crew interns so there can be a temporary supervisor. Programs with limited resources should be aware that if a regular permanent staff member takes on the task of supervising field crews, that person will need to have reduced workloads in other areas.
- **Additional considerations for citizen science projects.** Urban tree monitoring projects initiated by urban forestry professionals sometimes rely on citizen scientists for fieldwork (Roman et al. 2013). There are additional considerations for effectively managing these volunteer field crews. As unpaid crews, it is critical to ensure that their time is valued and that the data collection experience is meaningful, so that they are encouraged to volunteer again. With urban tree monitoring, fieldwork days could be organized as 1-day “mapping parties” in which volunteers get a quick morning training followed by data collection for preassigned plots. This approach has been used in New York City, NY (Silva et al. 2013). In another example, mapping events in Portland, Oregon, include arborists circulating by bicycle to offer assistance with species identification and other troubleshooting (di Salvo 2016). For planting cohort monitoring, the data collection may be done in tandem with tree maintenance or conversations with residents about stewardship. If that is the case, then volunteers will need additional training about how to approach those resident conversations and how to carry out appropriate maintenance. For example, volunteers with the Pennsylvania

---

Supervising field crews  
is not a side job.

---

Horticultural Society in Philadelphia, PA, knock on doors when they do urban tree monitoring to discuss proper watering, mulching, and staking techniques with residents who requested trees (Roman et al. 2018b). Volunteers then leave “report cards” for residents to note whether their maintenance techniques are done properly. When working with citizen scientists, it is important to acknowledge volunteers that devote significant time to the monitoring project by thanking them in newsletters or with award ceremonies. If using a mobile app, the citizen science project could take a gamification approach, whereby volunteers earn badges or other fun rewards for their service (Bowser et al. 2014, Crown et al. 2018). Additional resources for designing and implementing successful citizen science projects are available at the Federal Citizen Science and Crowdsourcing Toolkit website ([citizenscience.gov](http://citizenscience.gov)). Published examples of citizen science projects in urban forestry (including data quality issues) include Roman et al. (2017), Bancks et al. (2018), Crown et al. (2018), Hallett and Hallett (2018), Hamilton et al. (2018), and Roman et al. (2018b).

### 3.3. Field Equipment Suggestions

An equipment list for collecting the Minimum Data Set is included in the Field Guide (appendix 3). Specific equipment decisions will differ by project needs based on the size of the trees being measured, the social context of the study area (i.e., private versus public trees), and the financial resources of the study. Speaking with other project leaders is recommended to gather ideas about which equipment to use based on monitoring goals and budget. We list below considerations for measuring d.b.h. (from the Minimum Data Set) as well as total tree height and canopy width (from the Tree Data Set).

- **On measuring trunk diameter.** As previously mentioned, diameter tape (d-tape) is the most commonly used tool for measuring trunk diameter in forest ecology. This specialized forestry tool has regular units on one side—which can be used to measure circumference—and diameter units on the other side. This uses the classic formula from geometry:  $\text{circumference} = \text{diameter} * \pi$ . However, not all urban forest inventory and monitoring projects use d-tape. When the trees being measured are quite small—less than 1-inch (2.54 cm) d.b.h.—engineering **caliper tools** are more suitable (particularly digital calipers). Wrapping d-tape around a very small tree is quite awkward and requires holding the tape angled to read the value. Caliper tools can also be suitable for trunks that have obstructions (i.e., staking ties, vines) that would make it difficult to wrap a d-tape. Additionally, there are many kinds of d-tape available for purchase, of varying materials (e.g., fabric, stainless steel) and tape widths. For larger diameter trees, there are d-tapes with claw hooks on the end, so that hooks can be situated in the bark while a person wraps the tape around the tree, allowing one person to measure a large tree without assistance (e.g., fabric or steel 20-ft long tapes, 50+ ft heavy-duty logger tapes). Fabric d-tape (rather than stainless steel) can be easier to wrap around small to mid-size trees. However, when crews

---

Diameter tape (d-tape) is the most commonly used tool for measuring trunk diameter in forest ecology.

---

use fabric d-tapes, they will need to be careful to avoid stretching the fabric; d-tape should be pulled snug, but not too tight, around the trunk. Project supervisors should ensure that previously used fabric d-tapes have not stretched so much as to become inaccurate. For smaller trees (but greater than 1-inch d.b.h.), thinner “pocket” d-tapes are available (e.g., 6-ft thin-line tapes). Notably, Biltmore sticks—a forester’s tool to roughly measure d.b.h.—are not conducive to precise remeasurement of d.b.h. Likewise, d-tapes or caliper tools with coarse resolution (e.g., units displayed include only 0.5 inch) are inappropriate for projects that seek to measure d.b.h. growth over time; the resolution of such measurement devices is not fine enough to reflect the relatively slow growth of tree trunks. For projects using U.S. customary units, we recommend d-tapes that have inches and 1/10-inch units. For projects using metric units, we recommend d-tapes that have centimeters and millimeter units (see section 2.1.10).

In addition to d.b.h., our protocols in the Field Guide call for recording the height of diameter measurement (see Field Guide section 2.12.1). Although that height could be taken with the regular units side of the d-tape, it is generally easier to have a different piece of equipment solely for measuring that height. We recommend either a contractor-grade stiff measuring tape (similar to the measuring tapes that many people have for home use) or a custom-cut 4.5-ft (1.37-m) height pole (from a material like PVC). However, if using a custom-cut height pole, it would be necessary to have markings for other heights, for situations in which diameter is measured lower or higher than 4.5 ft (1.37 m). If using U.S. customary units, the markings could be at every 10th foot (and not foot with inch gradations). A manual height pole (sometimes called a telescoping survey rod) could also be used to measure height to the d.b.h. point. Whichever measuring tool is used to determine the height to the d.b.h. point, always note measurement units in the final database.

Crews should **not** use “breast height” on their bodies as a height reference, even though some crews may be familiar with this approach from prior coursework and field experiences. That approach may be acceptable when coarse d.b.h. measurements are needed (e.g., recording d.b.h. as being within a size class range of several inches), but it is not appropriate for d.b.h. when repeated growth measurements are intended.

- **On measuring tree height.** Tool choices for measuring total tree height include a manual height pole (also called telescoping measuring pole or survey rod), clinometer used in conjunction with measuring tape, and digital laser hypsometer. Equipment selection will depend on the general height of the trees. For short trees (<25 ft or 7.6 m), a height pole is recommended, as the crews can clearly see where the pole reaches the top of the tree. Clinometers or digital hypsometers are more appropriate for mid-size to tall trees, and such equipment has varying options for expense and accuracy.

- **On measuring crown width.** Options for measuring crown width include contractor-grade or household tape measuring tape and digital laser hypsometers. For small trees, a measuring tape is easy to use and quite adequate. When the tree crown width is large enough that a measuring tape is unwieldy, electronic devices such as hypsometers become preferable. See the Tree Data Set (section 7) for more information about options for recording crown width.
- **Use the same measuring tools across all crews and over time.** For consistency, it is important for all crews to use the same equipment and same units of measure. Projects initiated in U.S. customary units should stay in those units over successive monitoring years, and likewise for metric units. Remeasurements for growth particularly require using the same equipment as the previous data collection. If mixing equipment is unavoidable (e.g., borrowing equipment from different partners owing to limited costs, measuring some very short trees with manual height poles and some very tall trees with hypsometers), make sure to calibrate. In other words, measure the same trees with both pieces of equipment to ensure that differences between them are within a reasonable margin of error.

---

It is important for all crews to use the same equipment and same units of measure.

---

## 4. Conclusion

In this Resource Guide, we have described designing and implementing techniques for field-based urban tree monitoring projects. The main point is that advance planning is needed to ensure that monitoring projects run smoothly with well-organized data collection, and to produce findings that are ultimately useful for the project goals. The remaining sections of this Resource Guide address the background on variable selection for the Minimum Data Set, variables to consider for projects going beyond the Minimum Data Set, as well as various supporting documentation related to urban tree monitoring (e.g., species identification resources, glossary, activities for training). Collectively, these resources should enable customization for projects with varying goals and personnel experience levels. Although long-term data collection for urban trees is a relatively recent area of scholarship and resource management, we can build on the long traditions of tree monitoring in rural ecosystems, and learn from the experiences of researchers and practitioners who have been pioneering tree monitoring in urban areas.



---

## **Part II: Data Sets for Urban Tree Monitoring**

---

## 5. Data Sets Framework

We have organized the monitoring protocols into a Minimum Data Set and four supplemental data sets. This structure allows urban forestry practitioners and researchers to adapt these protocols to their own needs based on monitoring project goals and organizational capacity. See section 1.4.3 for examples of the protocols in action with adaptation to local monitoring goals.

The data sets are organized as follows:

- **Minimum Data Set.** The core variables necessary for any urban tree monitoring project, including field crew identification, field crew experience level, species, location, site type, land use, mortality status, crown vigor, and trunk diameter (section 6).
- **Tree Data Set.** Tree size, growth, and health variables, including total height, crown width, presence of pests and diseases, and maintenance tasks. Includes variables related to mature tree management (section 7).
- **Site Data Set.** The site characteristics of the urban landscape surrounding the tree, including the planting site, built environment, and soils (Urban 2008) (section 8).
- **Young Tree Management Data Set.** Recommended tree care practices by local organizations, and stewardship actions observed on the ground, and information about the programs and institutions that plant and care for trees (section 9).
- **Community Data Set.** Socioeconomic information about the human community surrounding the tree, pulled from existing databases (e.g., U.S. Census Bureau) for variables including median income, housing value, and population density. The Community Data Set does not require additional fieldwork but does require staff with GIS expertise (section 10).

The Field Guide provides detailed field protocols for only the Minimum Data Set. The Resource Guide provides lists of variables for each of the five data sets, with general descriptions, but without detailed field protocols; instead, we provide citations to other resources for readers interested in incorporating those variables into their project. We also provide explanations as to why some of the methods used in the Minimum Data Set were selected.

For most urban forest managers and even many research studies, the Minimum Data Set should be sufficient to meet monitoring program goals, such as evaluating performance in terms of mortality and growth or tracking

changes in total tree population counts. As stressed in section 1.3, we urge those designing monitoring studies to be cautious when adding other variables. Be certain that there is an intended use for every variable collected, that the methods match the objectives of the monitoring project, and that the field crews have the appropriate training and skills to accomplish the data-collection tasks.

Furthermore, the variables listed in each data set are not exhaustive of all possible variables that could be collected to monitor urban trees. For those interested in establishing monitoring studies with intensive fieldwork, particularly for tree and site variables, we recommend exploring the other tree inventory and monitoring protocols listed in appendix 3.

For each of the data sets, we list potential goals for monitoring studies that could be met by using that data set (or portions of it). We have also coded the data sets by tiers to represent different levels of difficulty. These tiers allow customization of the protocols based on field crew skill levels and available resources, in terms of field crew time, equipment, and post-fieldwork processing.

- **Tier 0: Basic.** This is the easiest data to collect and can be gathered in the field by crews with minimal training. For projects relying on volunteers and minimally trained interns, we recommend using only the Minimum Data Set.
- **Tier 1: Moderate.** This is more extensive field data, with a suite of variables from the Tree, Site, and Young Tree Management Data Sets, in addition to the Minimum Data Set. Interns and volunteers could still potentially collect these data, but more in-depth field crew training is required, and more time is needed per tree.
- **Tier 2: Difficult.** This is advanced field data collection that requires individuals with prior experience and specialized equipment. These options involve more background knowledge than the basic and moderate options, but do not necessarily take more time in the field.
- **Tier 3: Expert.** This data collection requires expert-level training and analysis in specialty areas, such as tree risk management, soil testing, and social sciences. Data processing and statistical analysis outside of fieldwork is also required for some components. We recommend that this level of data collection be undertaken in collaboration with experts, such as research scientists or master arborists.

Because the Community Data Set does not involve fieldwork, we do not have tiers for that data set. Instead, the Community Data Set involves accessing socioeconomic data from existing databases and is therefore organized according to data sources (e.g., U.S. Census Bureau, local crime data).

## 6. Minimum Data Set

The Minimum Data Set consists of information that allows practitioners and researchers to assess urban tree mortality, growth, and health. More specifically, the goals of the Minimum Data Set are to provide information to enable users to:

- Reliably locate trees for future fieldwork with different field crews.
- Identify and investigate errors associated with field data collection and conduct quality control/quality assurance.
- Report survival and mortality rates, and construct mortality curves by time since planting (planting cohort monitoring studies) or by d.b.h. size class (repeated census studies).
- Report d.b.h. growth rates.
- Report changes in foliage health over time.
- Analyze potential risk factors for growth and mortality that are included in the Minimum Data Set:
  - Age (time since planting) or size class (d.b.h.)
  - Species
  - Crown vigor
  - Site type
  - Land use

Studies using the Minimum Data Set can also connect to other information that does not require additional fieldwork but may be used for statistical analysis of mortality, growth, and health outcomes:

- Species groups (e.g., levels of drought or flood tolerance, natives versus nonnatives, mature tree size, as determined by textbooks and fact sheets on urban trees).
- Neighborhood socioeconomic characteristics (e.g., U.S. Census data, from the Community Data Set, see section 10).

Detailed protocols for the Minimum Data Set are provided in the Field Guide. The variables included in the Minimum Data Set are shown in Figure 3. We provide justification as to why each variable is included in the Minimum Data Set in the Field Guide (section 2). Below we provide brief descriptions of each variable plus some additional explanation as to how we decided upon specific protocols for mortality status, crown vigor, and trunk diameter.

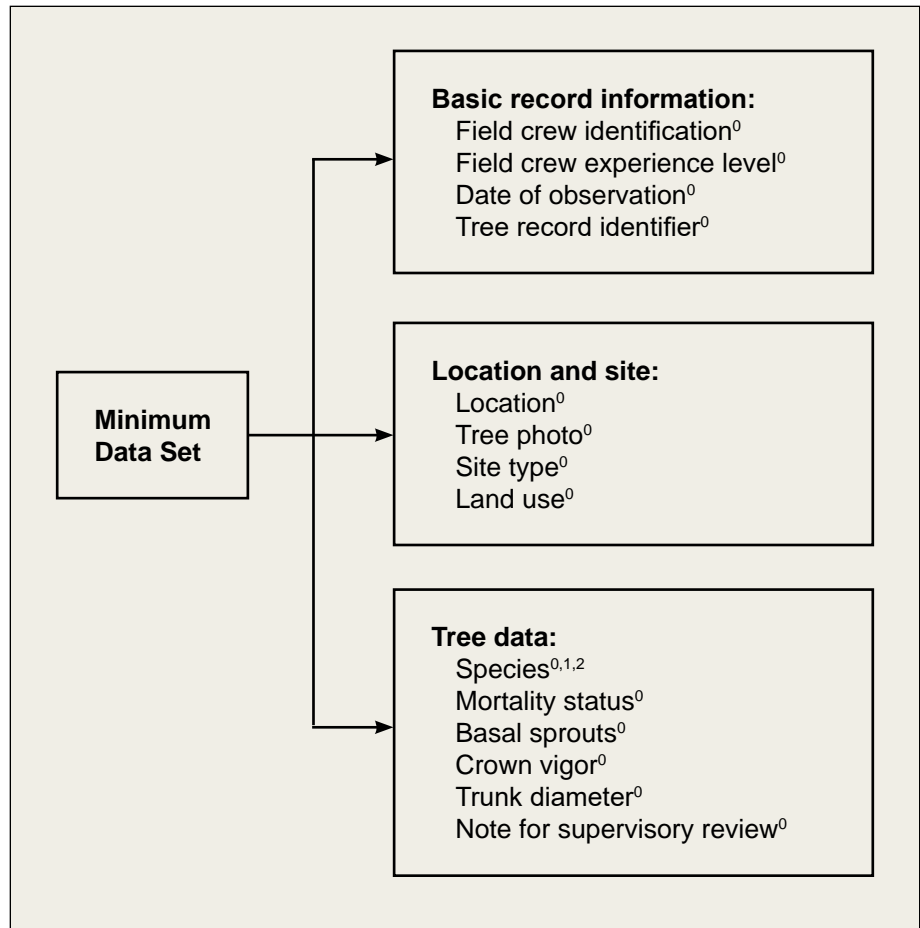

**Figure 3.**—Variables in the Minimum Data Set. Superscripts represent tiers (see section 5), with more than one tier indicating that crews with more skills or equipment could obtain enhanced data.

## 6.1. Basic Record Information

### 6.1.1. Field crew identification

Description: Field crew identification is information about the individual(s) who collected field data on this tree. Crew names, initials, or team numbers may be used but should be consistent within a given project.

### 6.1.2. Field crew experience level

Description: The experience level of the most experienced individual on the field crew team that collected data on this tree.

### 6.1.3. Date of observation

Description: Date (year, month, day) of the field data collection.

### 6.1.4. Tree record identifier

Description: Each tree record should have a unique identification code that remains connected to the tree during future monitoring. For projects that track recently planted trees, the unique key could link with planting records.

## 6.2. Location and Site

### 6.2.1. Location

Description: Information about the geographic position of the tree in the landscape, used to relocate the tree for future monitoring and to link this tree to other geospatial data sets. Different options for tree location methods are discussed in the Field Guide (section 2.4) and Resource Guide (section 2.3).

### 6.2.2. Tree photo

Description: A photograph taken to show the entire tree in the context of its immediate location and built infrastructure objects in the landscape, with a view that would help future field crews reliably find the same tree.

### 6.2.3. Site type

Description: Site type is a description of the tree's immediate location. The site type categories indicate broad information about the immediate area surrounding the tree and controls on tree inputs and removals (human-dominated versus natural).

### 6.2.4. Land Use

Description: Land use is a description of the way the property around (or adjacent to) the tree is used by humans. Land use is distinct from site type, although the two variables are related and there is some overlap in their definitions, particularly with parks and natural areas. We use land use to refer to land use at the property level, not at the tree site.

## 6.3. Tree Data

### 6.3.1. Species

Description: Record species using standard botanical names, with both genus and species, or species codes. When using species codes, we recommend the codes from the Urban Forest Inventory and Analysis program of the Forest Service (USDA FS 2017). These codes consist of the first two letters of the genus and species. For example, red maple should be recorded as *Acer rubrum* or species code ACRU. Crews with less species-identification skill could potentially record only genus information or only record the most common species (Roman et al. 2017).

### 6.3.2. Mortality status

Description: Mortality status is a record of whether the tree is alive, standing dead, removed, or in some other state.

### 6.3.3. Basal sprouts

Description: Basal sprouts, sometimes called suckers or water sprouts, grow from buds at the base of the stem or in the roots of a tree. Basal sprouts can indicate that the root system is still alive in a stump or standing dead tree. Record "present" if basal sprouts are present or "absent" if basal sprouts are not present. See section 2.1.17 for a discussion about deciding on the intended use of the basal sprout variable.

### 6.3.4. Crown vigor

Description: Crown vigor consists of five classes based on visual examination of crown health. It is a holistic assessment of overall crown health and reflects the proportion of the crown with foliage problems and major branch loss. Note that crown vigor does not involve evaluation of trunk condition or structural stability.

### 6.3.5. Trunk diameter

Description: Trunk diameter is recorded either as diameter at breast height (d.b.h.) or **diameter at caliper height** (d.c.h.), depending on the tree's characteristics: d.b.h. is the measure of diameter at 4.5 ft (1.37 m) from the ground, and d.c.h. is the diameter at 1 ft (30.5 cm) from the ground (using the meaning of caliper from the nursery trade, which is different from a caliper measuring tool). While d.b.h. is the standard way to measure trunk size for forest ecologists and most urban foresters, d.c.h. is the common way to report sizes of nursery stock. Measurements for trunk diameter include the diameter itself and the height at which the diameter is taken. The protocols in the Field Guide also have specific instructions for measuring multi-stemmed trees (see Field Guide section 2.12.4, and section 6.5 below, as well as Magarik et al. 2020). Note that while we recommend recording diameter, some project may prefer circumference, and this must be noted with data collection so that conversions can occur during data processing.

### 6.3.6. Notes for supervisory review

Description: This is a place to note difficulties with species, mortality status, trunk diameter measurements, or other variables. Entering a note here flags this tree for review by the project supervisor.

## 6.4. Background on Mortality Status

While mortality may seem like a fairly obvious variable to record, it has caused some confusion in urban forestry research and been defined in different ways. As noted in section 1.1.1, we define mortality as including trees that are observed standing dead and those that have been removed. This is consistent with dozens of prior studies on urban tree mortality (Hilbert et al. 2019). Yet even with mortality reflecting a combination of trees that die standing in place, and those that are removed, it is still helpful to differentiate removals from standing dead outcomes. The categories that we specified for mortality status are: alive, standing dead, stump, removed, never planted, and unknown (see Field Guide section 2.9).

Our reasoning behind these categories reflect both practical management considerations as well as research applications. For management purposes, standing dead trees require followup to remove them, and large standing dead trees can create risks for human safety and property damage. Using a

similar rationale, we include stump as a category within mortality status; arborists may want to know where stumps are located so that workers can subsequently grind up the stumps. Recording standing dead trees as their own category, separately from removed trees, also has value for research studies. For example, in a multi-age inventory street tree monitoring study in Oakland, California, trees were monitored for mortality annually for 5 years (Roman et al. 2014b). Transitions in the street tree population were tracked, in terms of new trees, dying trees, and removals. The average proportion of trees observed standing dead was 1.7 percent. Yet many of these trees persisted in the landscape over time, remaining dead rather than being removed: of the standing dead trees observed in a given year, on average, 56.7 percent were removed by the following year. These findings point to the lack of followup care to handle dead tree removals in the study area.

The category of “never planted” within mortality status was created for planting cohort studies, in recognition of urban forestry programs that operate as giveaways (Nguyen et al. 2017). Such programs distribute trees, typically to residents, who are then responsible for planting. However, not every tree distributed will actually get planted by the residents in their yards. For example, in a yard tree giveaway program in Sacramento, CA, 15.1 percent of trees distributed were not planted (Roman et al. 2014a). While failure to plant and post-planting mortality are both problems for the program, they are distinct phenomena with potentially different causes. The never planted category in mortality status enables field crews to track that outcome. Notably, for giveaway programs, using field data alone, it can be challenging to distinguish between trees that residents never planted versus trees that were planted and subsequently removed. Discussions with residents may be necessary to determine what happened to any “missing” trees.

While the never planted category is certainly necessary for cohort monitoring of yard tree giveaway programs, it can also be relevant to tracking street tree planting programs. The at-planting records for street tree programs might erroneously contain trees that did not get planted for one reason or another (Roman et al. 2018b), such as last-minute refusal by an adjacent property owner, or unexpected utilities underground.

Finally, we included the unknown category within mortality status because of the unusual cases that can arise in urban tree monitoring. This includes situations of “zombie trees” discussed in section 2.1.16, as well as any instances in which there is locational confusion finding the tree from baseline records. Although field crews will rarely assign a tree to unknown mortality, we have it as an option to capture those unique situations, so that project supervisors can resolve them later.

## 6.5. Background on Crown Vigor

There are many options for recording urban tree health and condition, many of which are reviewed in Bond (2010). Other protocols for evaluating tree health that have been applied to urban areas include Bond (2012), Östberg et al. (2013), Pontius and Hallett (2014), and Vogt and Fischer (2014). Many methods for visually evaluating tree health, condition, vigor or vitality require prior knowledge about the typical performance of various tree species in the region of study. This approach is challenging to implement for many intern and volunteer field crews, so we wanted to pursue a means of evaluating the tree that required less prior expertise.

For the final Minimum Data Set, we used the crown vigor variable based on Pontius and Hallett (2014), which in turn is based on protocols used for the North American Maple Project (NAMP) (Millers et al. 1991, Steinman 1998,) and used to study regional sugar maple decline disease (Hallett et al. 2006). While this variable was not tested in the Field Guide pilot study, it was separately evaluated in a study of urban tree inventory data quality from high school students (Hallett and Hallett 2018), which showed that student crews were within one vigor class of expert crews for 56 percent of trees, and within two vigor classes for 92 percent of trees. In a study of monitoring data from recently planted trees, volunteer vigor was within one class of intern vigor for 90 percent of trees (Roman et al. 2018). Notably, the Hallett and Hallett (2018) study also involved recording discoloration and defoliation separately, which may be of interest to some tree monitoring studies that seek more in-depth data about tree health trends to detect stress response and decline over time. That approach has been used to study the stress response of street trees that were flooded by salt water during Hurricane Sandy in New York City, NY (Hallett et al. 2018).

Readers of this report may prefer one of the other protocols for visually evaluating urban tree health cited in the first paragraph of this section, rather than crown vigor as defined in the Field Guide. Whichever method is chosen, we strongly encourage using variables for health, condition, dieback, vigor, or vitality with clear definitions and rubrics that distinguish among classes. We also strongly advise limiting evaluations of wood condition, structural stability, and maintenance or pruning needs to certified arborists or comparable experts, based on findings of Bloniarz and Ryan (1996), Cozad (2005), and Roman et al. (2017). For further guidance regarding variables specific to tree health and wood condition, see the Tree Data Set (section 7).

It is important to note that all of the methods for evaluating tree health, condition, dieback, vigor, or vitality are designed for deciduous or evergreen trees, generally in temperate climates. However, cities in tropical, subtropical, or Mediterranean climates also often have palms as part of their urban forests. A recent publication provides guidance about a visual health assessment method for palms (Blair et al. 2019).

## 6.6. Background on Trunk Diameter

While d.b.h. is a core component of nearly all urban tree inventory and monitoring methods (Bond 2013, Östberg et al. 2013, Roman et al. 2013), we have found that many urban forestry professionals record d.b.h. in a manner that is not conducive to assessing tree growth over time. Specifically, d.b.h. is often recorded to the nearest 1 inch (2.54 cm), and height to diameter measurement point is not noted. That approach is appropriate for inventories that serve management purposes, such as using d.b.h. to place work orders for tree removal, or constructing basic graphs of tree size class distribution. However, such coarse d.b.h. data precludes analysis of trunk growth, and more precise d.b.h. data are needed for analyses of ecosystem services such as carbon sequestration. It is worth re-emphasizing that although the default height for d.b.h. is 4.5 ft (1.37 m) in the United States, and this is the height specified in our Field Guide, the actual measurement height used for each individual tree may differ owing to tree form and trunk irregularities (see Field Guide “Special Considerations” for d.b.h., section 2.12.3).

The variation in actual height used for d.b.h. leads researchers in forest ecology to employ strategies for ensuring that future remeasurements on individual trees are done at the same height point. One strategy is to use a custom-cut 4.5-ft (1.37-m) pole (van Doorn 2014) so that future crews can wrap d-tape at the exact same spot on the tree. Permanent plots in forest ecology research also sometimes mark the point of d.b.h. measurement with paint, permanent markers, aluminum nails, or crayons (Condit 1998, USDA FS 2017a). However, urban forest managers may not wish to have trees nailed or painted, as these techniques might be considered unappealing aesthetically, or upsetting to residents. Temporary solutions such as chalk may aid in the process of recording height to d.b.h. measurement point (Magarik et al. 2020) while longer lasting solutions such as permanent marker can carry over from season to season. Yet even without marking the tree, if crews carefully measure the height to the initial d.b.h. measurement point, it is possible to remeasure d.b.h. at the same spot in future years, ultimately enabling assessment of growth.

Trees are also generally slow-growing organisms, so measuring trunk growth with precision requires recording d.b.h. to the nearest 10th inch (or if using metric, nearest millimeter), which is standard in forest ecology plots. This same approach can be applied to urban trees—which is why the protocols in the Field Guide call for measuring to the nearest 10th-inch (or millimeter). For example, the combination of nearest 10th-inch measurements and records of the exact d.b.h. height used enabled Roman et al. (2015) to report annual growth rates for recently planted trees in Philadelphia, PA: *Quercus palustris* grew at 1.9 cm (0.75 inches) per year, whereas *Acer rubrum* grew at 1.1 cm (0.43 inches) per year. Initial measurements were taken 1 month after planting, and trees were remeasured 6 years later.

Trees that fork below 4.5 ft (1.37 m)—often referred to as multi-stemmed trees—create distinct challenges for measuring d.b.h. The treatment of multi-stemmed trees in our Field Guide is based on lessons learned in the pilot test (Roman et al. 2017), in which citizen scientist crews sometimes disagreed with each other regarding how many stems a particular tree had, even though they were given guidance for how to decide which stems to measure. Some crews in that study also commented that multi-stem d.b.h. measurements were difficult. In our other experiences using conventional multi-stemmed protocols, such as the directions to measure up to six stems in i-Tree Eco (i-Tree 2017b), paid intern crews and even experts have similarly expressed challenges. Ultimately, the coauthors of that pilot study (Roman et al. 2017) concluded that trunk measurements at 4.5 ft (1.37 m) are not well-suited to small-statured, ornamental, multi-stemmed tree species that are common in urban forests. Furthermore, recording multiple stems does not seem conducive to careful remeasurement of trunk growth, as future field crews cannot be guaranteed to remeasure the exact same stems, especially with the possibility for pruning. This led to our guidelines to measure d.b.h. below the fork, where there is a single stem, whenever possible. This technique also draws inspiration from practical methods for d.b.h. geared toward professional arborists (Swiecki and Bernhardt 2001). We posit that measuring below the fork should produce more consistent results across field crews and over time, thus enabling analysis of tree growth.

However, besides diameter below fork, there is another approach to measuring multi-stemmed trees that may be well-suited to consistent remeasurements over many years: diameter at 1 ft (30.5 cm) from the ground. A field evaluation study of *Malus* spp., *Prunus* spp., and *Zelkova* spp. street trees in Philadelphia, PA, showed that this approach had the most consistent heights to measurement point, unlike diameter below fork, where variation in height is inherent in the method (Magarik et al. 2020). In that study, there was no decisive advantage for any diameter measurement method in terms of predictive power for correlations with total tree height and crown width, making issues of consistency and repeatability paramount in method selection. Indeed, diameter at roughly caliper height is already used for nursery stock (American Nursery & Landscape Association 2004) as well as by various researchers for multi-stemmed trees in other ecosystems (MacDicken et al. 1991, Snowdon et al. 2002, Stewart and Dunsdon 1994, Stewart and Salazar 1992). Measuring diameter at 1 ft (30.5 cm) may be most appropriate for researchers concerned with consistency across space and time. However, as this study was limited to three genera in one city, further research is needed to evaluate pros and cons of various options for measuring multi-stemmed urban trees for different taxonomic groups and growing conditions. Different approaches to measuring multi-stemmed trees can have implications for analyses of tree growth, allometry, and ecosystem services.

Notably, the study about multi-stemmed trees in Philadelphia (Magarik et al. 2020) also employed notation for reporting diameter height that makes it easier to communicate the default, standard height: the letter “D” followed by a subscript with the height from the ground in centimeters (e.g.,  $D_{30.5}$  for diameter at 30.5 cm,  $D_{137}$  for diameter at 137 cm, following Brokaw and Thompson 2000). This notation may be particularly helpful in comparing d.b.h. methods and findings across countries, as  $D_{137}$  is standard in the United States, but  $D_{130}$  is the norm in Europe and the most common standard in forest ecology studies, although many publications do not even report the diameter height used (Brokaw and Thompson 2000).

## 7. Tree Data Set

The Tree Data Set consists of information that allows practitioners and researchers to assess tree growth as well as health, presence of pests and diseases, maintenance requirements, and risk. The variables included in the Tree Data Set are shown in Figure 4. For those who are thinking of including variables in addition to the Minimum Data Set, we encourage focusing on the variables that are marked with “1” and “2” (meaning the attainment effort is lower; see Figure 4).

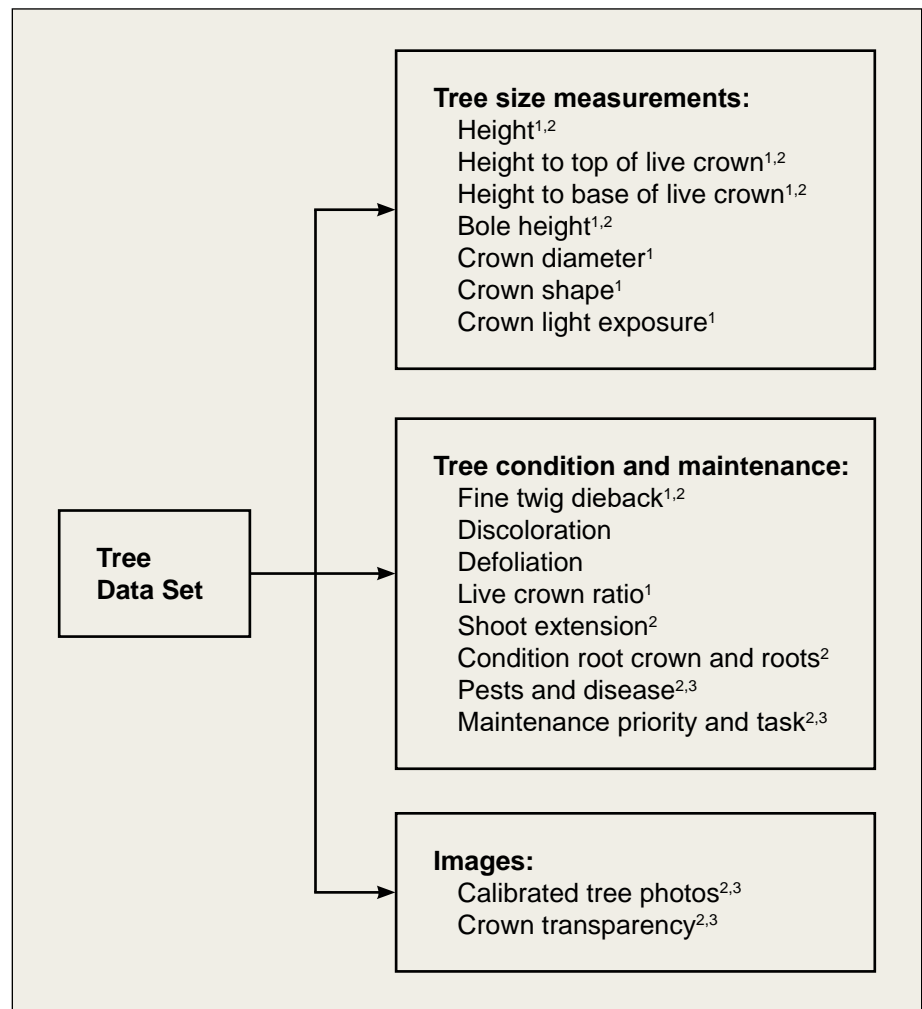

**Figure 4.**—Variables in the Tree Data Set. Superscripts represent tiers (see section 5), with more than one tier indicating that crews with more skills or equipment could obtain enhanced data.

Note that maintenance variables in this data set are most relevant to mature urban trees, whereas maintenance and stewardship variables related to young trees during establishment are in the Young Tree Management Data Set.

More specifically, the goals of the Tree Data Set are to provide information that will provide users the ability to:

- Monitor tree growth with regards to height and crown size and develop allometric equations relating d.b.h. to these other tree size measurements.
- Assess and monitor tree health to detect stress response.
- Assess management considerations, specifically pruning, tree risk, and potential for infrastructure conflict owing to tree size or growth habit.
- Provide sufficient information to calculate ecosystem services for other applications such as i-Tree Eco (USDA FS 2017b) and EcoSmart Landscapes (McPherson et al. 2014), and carbon credits with the Climate Action Reserve (Climate Action Reserve 2018).
- Provide baseline data for evaluation of site and soil impacts on tree growth and condition (in conjunction with Site Data Set).

In the tree health variables below, fine twig dieback, discoloration, and defoliation are based on assessment methods described in Pontius and Hallett (2014), Hallett and Hallett (2018), and Hallett et al. (2018).

## 7.1. Tree Size Measurements

Variables previously described in i-Tree Eco (2017a) and UFIA protocols (i-Tree 2017b) are cited in parentheses with matching or similar terms and page numbers.

### 7.1.1. Height (total)

Description: Total tree height from the ground to the top of the crown measured vertically (i-Tree 2017a, p. 28).

### 7.1.2. Height to top of live crown

Description: Height from the ground level to the top of the live (green) crown vertically (i-Tree 2017a, p. 28).

### 7.1.3. Height to base of live crown

Description: Distance between the ground and the bottom of live foliage of the crown (i-Tree 2017a, p. 29).

### 7.1.4. Bole height

Description: Measurement of the length of the bole from the ground level to the first crown-forming branch. This is sometimes called trunk height or clear bole height. On palm trees, measure stem from the ground to leaf base (apical meristem; base of the heart leaf; also known as trunk height in palm standards).

### 7.1.5. Crown diameter

Description: Two horizontal perpendicular widths from leaf or twig tip (dripline), passing through the trunk. There are three options for recording those crown widths: (1) record the widest diameter of the crown first, then the diameter perpendicular to that, following UFIA (USDA FS 2017, p. 142); (2) record width in the north-south and east-west cardinal directions, following i-Tree Eco (2017a, p. 30); and (3) for street trees, record diameter parallel and perpendicular to the street, following McPherson et al. (2016). The street tree method is often equivalent to UFIA because of typical pruning practices along roads. We are not aware of studies that compare these options for the same trees, so we recommend that monitoring project leaders pick one of these options and use it consistently for a given study.

### 7.1.6. Crown shape

Description: “Crown shape is the silhouette of a tree, drawn from branch tip to branch tip, which contains all of a tree’s foliage. Normally, silhouettes are derived from vigorous, open grown trees and tend to be species specific. Crown shape is used as an outline for the sides of the tree” (USDA FS 2017, p. 156).

### 7.1.7. Crown light exposure

Description: Tree crowns are divided vertically into four equal sides (or quarters) plus the top for a possible total of five faces. Count how many of the four sides would receive direct light if the sun were directly above the tree. Try to divide the crown in such a way that as many quarters as possible receive full light. Add one if the tree receives direct light from the top (USDA FS 2017a, pp. 161-162, 173; USDA 2017b, p. 35).

## 7.2. Tree Condition and Maintenance

### 7.2.1. Fine twig dieback

Description: Fine twig dieback indicates the death of tissues responsible for producing and supporting most of a tree’s leaf surface area and branch elongation. The amount of fine twig dieback is a reflection of the severity of recent stresses on the tree. Fine twig dieback reflects the percentage of crown area affected, focusing specifically on the upper and outer sections of the crown. The fine twig dieback variable is focused on recent stress response in the fine twigs rather than natural branch dieback (self-pruning owing to crown competition or shading in the lower portion of the crown), older branch mortality, or pruned sections of the crown.

Fine twig dieback reflects the percentage of crown volume affected (Box 1). Therefore, a tree with a single branch with dieback can have a large percentage of dieback if the overall crown is small, while a tree with a large crown and a comparable branch with dieback will have a much smaller percentage of dieback. See pictures in Box 1 for examples. Walk around the tree to observe fine twig dieback from several angles and record the average. If completing the survey as a field crew team, attempt to reach consensus for the dieback class.

The fine twig dieback description here is based on i-Tree (2017a, 2017b).

### Box 1. Fine twig dieback classes

Dieback class	Percentage of crown showing dieback
1	0-1 (none/trace)
5	2-5
10	6-10
15	11-15
20	16-20
25	21-25
30	26-30
35	31-35
40	36-40
45	41-45
50	46-50
55	51-55
60	56-60
65	61-65
70	66-70
75	71-75
80	76-80
85	81-85
90	86-90
95	91-95
99	96-99



A tree with fine twig dieback. Photo by J.P. Fristensky, used with permission.



Class 5: 2 to 5 percent fine twig dieback. The difference between the red dashed outline and the outer black outline represents the percentage of fine twig dieback. Overlay by J.P. Fristensky, used with permission.

### **7.2.2. Discoloration**

Description: Foliar discoloration is the proportion of the tree canopy with different coloration than a healthy tree of the same species. Possible symptoms include dark spots on leaves or leaves that are yellow, brown, or even lighter in color than a healthy tree of that species. For instance, there are some horticultural varieties of trees where the normal healthy leaf color is bronze or dark red or yellow. The rating applies to the total proportion of the canopy that is affected.

### **7.2.3. Defoliation**

Description: Defoliation applies to the proportion of the tree canopy with defoliation (holes in leaves or missing portions of leaves). The rating applies to the total proportion of the canopy that is affected. If 100 percent of the leaves have defoliation, the defoliation rating is not 100 percent (i-Tree 2017a, pp. 144-151, pp. 30-31).

### **7.2.4. Live crown ratio**

Description: The percentage of the total height of the tree that is occupied by the live green crown. When the top of the tree and the top of the live crown are in the same location, tree height and height to base of live crown are the only measurements required. If the top of the tree is dead, then height to the top of the live crown is also required (USDA FS 2017a, pp. 139-141).

### **7.2.5. Shoot extension**

Description: A measure of tree health understood as shoot extension. Determined from canopy parameters (Levinsson et al. 2017).

### **7.2.6. Condition root crown and roots**

Description: An assessment of planting practices; measure of circling, girdling, or compressing roots currently present on the root crown and potential circling, girdling, or compressing roots (USDA FS 2017a, pp. 178-179, 187-188, 189-190).

### **7.2.7. Pests and diseases**

Description: Information about pests and diseases can be recorded in two primary ways: (1) presence/absence of specific pests and diseases, or (2) signs and symptoms of specific pests and diseases. For protocol examples, see USDA FS (2017) and i-Tree (2017b).

### **7.2.8. Maintenance priority and task**

Description: Arborists and trained workers (tier 2) add mutually exclusive maintenance details that pose a possible hazard and should be inspected by more qualified personnel. Arborists who have passed the Tree Risk Assessor Course and Exam (TRACE) or taken the Tree Risk Assessment Qualification (TRAQ) course (tier 3) can collect data pertaining to risk and hazard, including the likelihood of failure, size of part which may fail, and target rating. The collection criteria and attributes are fully explained in the TRAQ course.

## 7.3. Images

### 7.3.1. Calibrated tree photos

Description: Profile views of tree taken perpendicular to one another (i.e., if one is taken facing north/south, the other faces east/west; alternatively, if one is facing the tree parallel to the street, the other is facing perpendicular) with distance between camera and tree bole recorded for each. When images are to be used for measurement of tree components like height and height to crown base, a scale must be placed on the bole of each photographed tree or another scaling method developed.

### 7.3.2. Photos to estimate crown transparency

Description: Four photographs taken as vertical images, each with the camera lens pointing up through one-quarter of the tree crown. Digital photographs can then be used to quantify the percentage of open versus dark pixels (Pontius and Hallett 2014). Digital images are automatically processed using a script written for CellProfiler (Lamprecht et al. 2007), which reports percentage transparency for each image. Transparency values from up to four photographs per tree can then be averaged to represent overall percentage of crown transparency. Careful records must be kept to ensure that each photo is associated with the correct tree, and the photographs are organized and curated for processing.

## 7.4. Background on Fine Twig Dieback

For the pilot test of the Field Guide, the protocol development team devised condition ratings for the tree's crown and wood, with a clearly defined four-part scale for each (Roman et al. 2017). The crown component was further divided into dieback and transparency, which were deemed to be variables that crews could collect without consideration of species-level patterns. We used 25 percent bin sizes for both of those variables (i.e., 0 to 25 percent dieback, 26 to 50 percent, etc.). The intent was to provide a system that mirrored the four-part scale of tree condition in i-Tree Streets (i.e., good, fair, poor, dying), but with more clearly defined categories. However, in the pilot test, we found that volunteer field crews were not consistent with experts for transparency and wood condition (Roman et al. 2017), and, therefore, those variables were dropped from the Field Guide. We kept fine twig dieback in the Tree Data Set and opted to use the more holistic crown vigor variable in the Minimum Data Set. With the fine twig dieback description in the Tree Data Set, we used the 5 percent bin sizes used by the protocols for i-Tree Eco, FIA, and UFIA (i-Tree 2017a; USDA FS 2016, 2017). Most trees recorded in the pilot study had <25 percent dieback; therefore, the 5 percent bins could potentially reveal important differences in dieback in the range of 0 to 25 percent. However, we recognize that there is ongoing debate as to how fine twig dieback should be recorded, with other studies opting for 10 percent bins (Vogt and Fischer 2014). Further research is needed to determine levels of agreement among field crews for dieback depending upon the bin sizes, as well as optimal ways to train field crews to visually discern dieback. We also suspect that crews may sometimes include large branch mortality as part of fine twig dieback; this is not correct protocol, as fine twig dieback is

intended to focus on recent growth in the outer portions of the crown (Roman et al. 2017). Training for this variable should include photos of varying levels of fine twig dieback, as it can be difficult to encounter a range of situations during outdoor training.

## 8. Site Data Set

The Site Data Set consists of information that allows practitioners and researchers to assess site quality of urban landscapes for trees and forests. The variables included in the Site Data Set are shown in Figure 5. The goals of the Site Data Set are to provide information to address the following issues:

- Differentiate site conditions for their potential effects on urban trees and forests.
- Assess and monitor urban infrastructure (roads, buildings, sidewalks, and utilities) for their potential impact on tree mortality, growth, and health.
- Assess and monitor urban infrastructure for impacts on trees and potential maintenance concerns.
- Assess and monitor growing space for urban trees and forests.
- Assess and monitor management approaches to remediate urban soil quality.

Most of the Site Data Set is adapted from the Rapid Urban Site Index (Scharenbroch et al. 2017). Note that there are other resources available for characterizing and managing urban soils (Lindsey and Bassuk 1991, 1992; Scharenbroch et al. 2005, 2018; Scharenbroch and Catania 2012; Urban 1992, 2008). Research on nutrients and contaminants in the soil should be done in partnership with a soil science specialist.

### 8.1. Roads

#### 8.1.1. Type

Description: The type of the nearest road, classified by functions such as arterial, collector, and local (USDOT FHWA, n.d.). These data may be available from local planning agencies or could be assessed in the field.

#### 8.1.2. Distance

Description: The distance from the center of the tree trunk to the nearest road.

#### 8.1.3. Azimuth

Description: The cardinal direction or angular distance expressed as the direction one is facing when standing at the tree to the nearest point of the road.

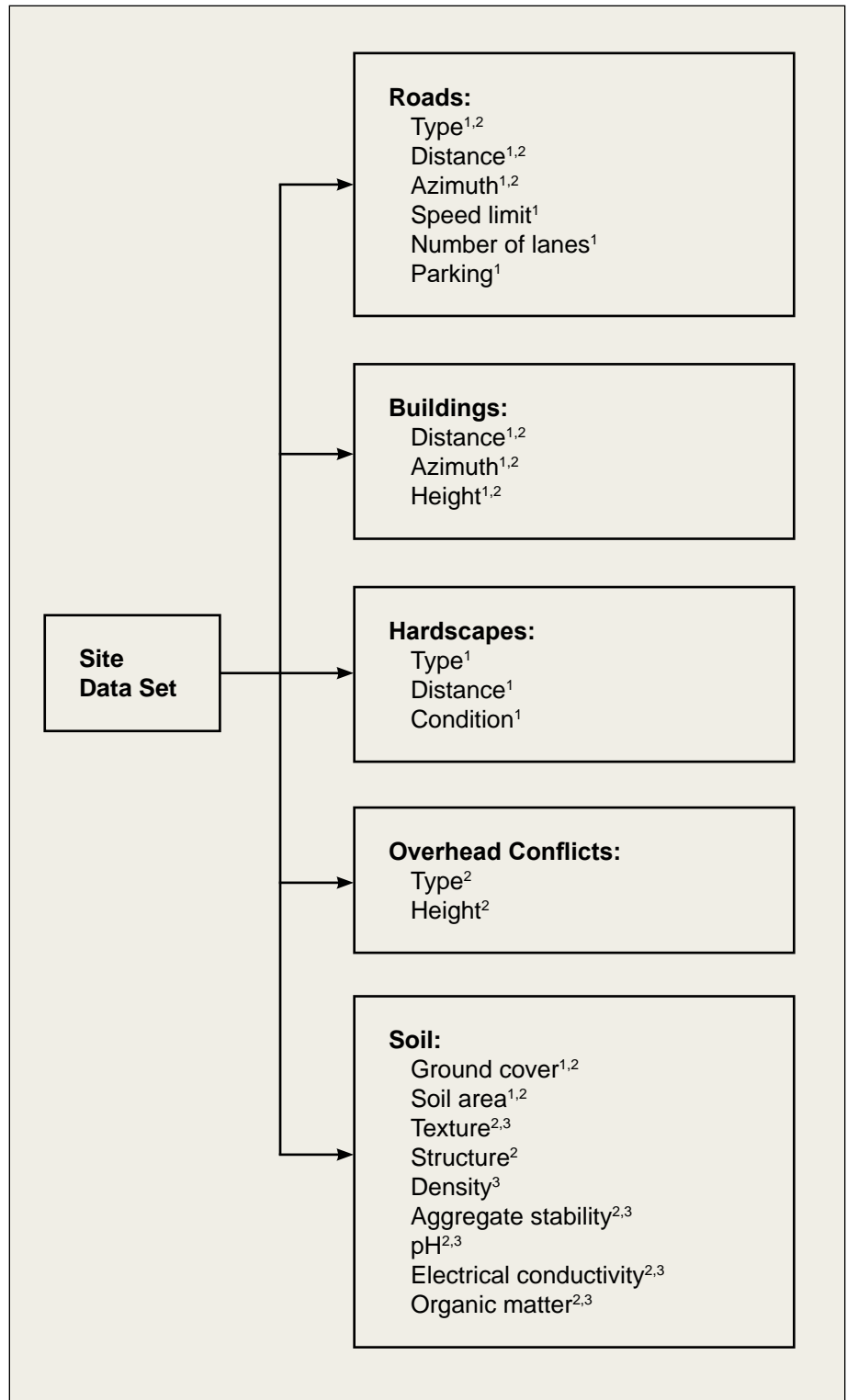

**Figure 5.**—Variables in the Site Data Set. Superscripts represent tiers (see section 5), with more than one tier indicating that crews with more skills or equipment could obtain enhanced data.

#### **8.1.4. Speed limit**

Description: The posted speed limit on the road.

#### **8.1.5. Number of lanes**

Description: The number of lanes on the road, excluding lanes of parking, but including turn lanes that run along the entire road segment.

#### **8.1.6. Parking**

Description: Parking available on the side of the road on which the tree is located.

### **8.2. Buildings**

#### **8.2.1. Distance**

Description: The distance to the nearest building.

#### **8.2.2. Azimuth**

Description: The cardinal direction or angular distance expressed as the direction one is facing when standing at the tree to the nearest point of the building.

#### **8.2.3. Height**

Description: The number of stories or height of the nearest building.

### **8.3. Hardscapes**

#### **8.3.1. Type**

Description: The type of the hardscape nearest to the tree.

#### **8.3.2. Distance**

Description: The distance to the nearest hardscape.

#### **8.3.3. Condition**

Description: The condition of hardscape. These data may include type, amount, or severity of distress to pavement (McPherson and Muchnick 2005, MTC 1986).

### **8.4. Overhead Conflicts**

#### **8.4.1. Type**

Description: The type of conflict present on the site, such as overhead wires, classified by functionality (e.g., primary lines carry electricity to substations; secondary lines carry electricity from the utility pole lines to a building; cable television and broadband lines provide cable and Internet services; telephone lines deliver landline telephone service).

#### **8.4.2. Height**

Description: The height from the ground to the conflict closest to the tree (e.g., height from the ground to the primary electrical line).

## 8.5. Soil

### 8.5.1. Ground cover

Description: The type of ground cover surrounding the tree.

### 8.5.2. Soil area

Description: An estimate of the soil area available for root growth that is directly accessible to the tree (also called “apparent available soil”) (Sanders and Grabosky 2014).

### 8.5.3. Texture

Description: Soil texture is a qualitative classification to distinguish the relative contributions of sand, silt, and clay in the soil.

### 8.5.4. Structure

Description: Soil structure is the physical arrangement of solid parts of the soil and the pores between them. Medium and fine-size aggregates produce numerous pore spaces which allow for root penetration, water storage, and movement of organisms, nutrients, air, and water through the soil.

### 8.5.5. Density

Description: Density can be assessed as soil bulk density or penetration resistance. Soil bulk density is the ratio of oven-dried soil mass to its bulk volume, inclusive of particles and pore spaces. Penetration resistance is a measure of the ease with which an object can be pushed into the soil. It gives an indication of root-impeding layers in the soil and can be used in comparing relative strengths among similar soil types.

### 8.5.6. Aggregate stability

Description: Aggregate stability is a measure of the vulnerability of soil aggregates to external destructive forces.

### 8.5.7. pH

Description: Soil pH is a measure of the acidity or alkalinity of a soil.

### 8.5.8. Electrical conductivity

Description: Soil electrical conductivity refers to the amount of salts (cations or anions) in the soil.

### 8.5.9. Organic matter

Description: Soil organic matter consists of plant and animal residues at various stages of decomposition, cells and tissues of soil organisms, and substances synthesized by soil organisms.

## 9. Young Tree Management Data Set

The Young Tree Management Data Set captures “rules in use” related to young tree care and management. The variables included in the Young Tree Management Data Set are shown in Figure 6. These rules or strategies are likely facilitated through a program of some sort—thus, data are collected about the program and its policies related to tree maintenance or stewardship (i.e., the actions that are supposed to happen to ensure proper tree care). Such information can be collected from the office. Corresponding field data records maintenance or stewardship actions happening on the ground are the “rules in use.” The goals of the Young Tree Management Data Set are to provide information to address the following issues:

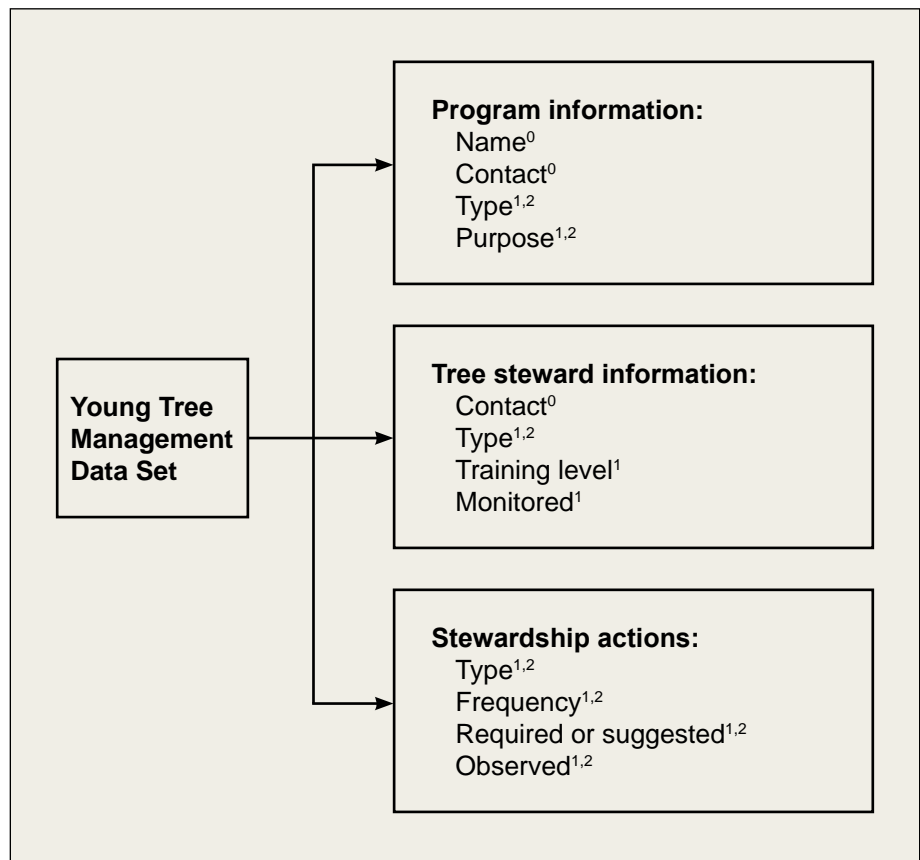

**Figure 6.**—Variables in the Young Tree Management Data Set. Superscripts represent tiers (see section 5), with more than one tier indicating that crews with more skills or equipment could obtain enhanced data.

1. Differentiate tree growth, mortality, and health outcomes across programs, program types, and steward characteristics.
2. Assess level of adherence to program-based maintenance rules or recommendations.
3. Associate observed maintenance with tree growth, mortality, and health.

## 9.1. Program Information

### 9.1.1. Program name

Description: If the tree was planted as part of a program, note that program's name. A program might include a municipal, regional, or nonprofit planting initiative (e.g., NeighborWoods, Plant-a-Million). If there are multiple programs relating to a single tree, record all programs. The other program-specific variables below relate to each program.

### 9.1.2. Program contact information

Description: Name and contact information for the leader or representative of the program.

### 9.1.3. Program type

Description: Categories of program type include municipal, county, state, other governmental, nonprofit, community/civic, utility, and business. Government programs could be subdivided by departments (e.g., parks and recreation, transportation). Multiple answers are allowed for one program, indicating partnerships.

### 9.1.4. Program purpose

Description: Categories of program purpose based on coded program mission statements, including generic planting/greening, targeted ecosystem service (e.g., stormwater runoff reduction, energy savings through tree shade), public engagement, equity, residential giveaway, canopy cover goal, and plant-a-million goal.

## 9.2 Tree Steward Information

The following information could be collected if there is a structured stewardship or a maintenance component to the tree planting program.

### 9.2.1. Steward contact

Description: Name and contact information for the leader or representative of the stewardship activities.

### 9.2.2. Steward type

Description: A categorization of the steward, including program staff, adjacent resident, adjacent business (or organization), neighborhood volunteer, organized stewardship group, other volunteer, and contracted entity (e.g., landscapers).

## 9.3. Stewardship Actions

### 9.2.3. Steward training level

Description: A measure of the expertise of the steward. Options could be similar to the field crew experience level in the Minimum Data Set (see Field Guide section 2.1.2), with stewardship training levels ranging from novice to intermediate to expert.

### 9.2.4. Steward monitored

Description: Binary (yes/no) indicator of whether the steward is required to report his/her activities to another party or otherwise monitored by the program to check on the steward's actions.

### 9.3.1. Stewardship action type

Description: Categories of types of stewardship activities that are relevant to tree growth, mortality, and health. Categories could include watering, pruning, mulching, staking, fertilizing, soil aeration, tree guard management, and pest monitoring/treatment. The other variables pertaining to stewardship actions below are recorded separately for each action type.

### 9.3.2. Stewardship action frequency

Description: Categories describing how often each stewardship task is completed.

### 9.3.3. Stewardship action required or suggested

Description: Whether or not the program requires or suggests this tree stewardship action.

### 9.3.4. Stewardship action observed

Description: For each stewardship action, record whether that action was observed to have occurred in the field. Less experienced field crews could record presence/absence of the action, while more experienced crews could observe varying degrees of correct/incorrect maintenance (e.g., different kinds of mulching problems).

## 10. Community Data Set

The Community Data Set consists of demographic, socioeconomic, property, and household information related to the geographic area near a tree. The variables included in the Community Data Set are shown in Figure 7. Such data can assist practitioners and researchers in analyzing the impact these factors may have on urban tree growth and mortality. Specifically, the goals of the Community Data Set are to:

1. Identify key variables such as population density, property values, education rates, and other demographic and socioeconomic factors, including household or consumer-specific information that may relate to tree growth, mortality, and health.
2. Specify a level of geographic extent (e.g., census tract, ZIP code, neighborhood) for use in analyzing data.

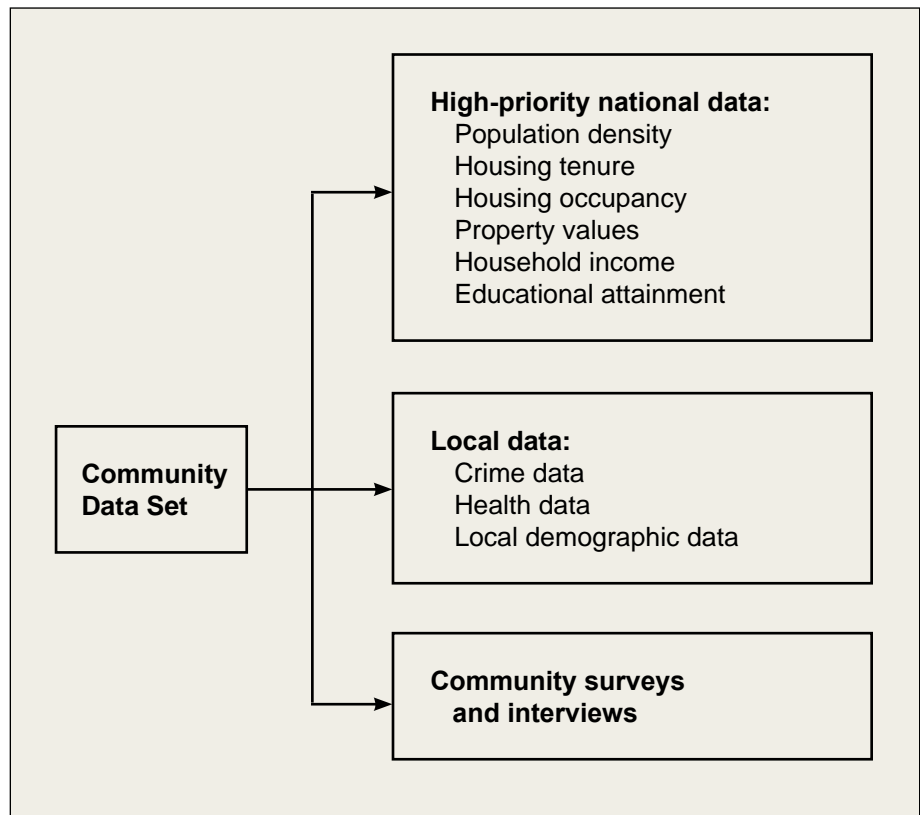

**Figure 7.**—Variables in the Community Data Set.

Note that the Community Data Set is grouped by types of data sources, rather than tiers representing field crew skill levels and available resources. This is because the Community Data Set is not based on field data collection on individual trees. Some of the variables relate to existing data sets available through national public resources, such as the U.S. Census Bureau. Other information related to the human community surrounding urban trees could require extensive mail or Internet surveys, or in-person interviews with residents. We have not provided detailed guidance regarding social science methods to collect such data. We recommend collaborating with social science researchers or geospatial analysts to collect and interpret these data in relation to tree monitoring.

## 10.1. High-Priority National Data

Within the United States, these variables can generally be obtained from the U.S. Census Bureau or American Community Survey and the data associated with trees at the census tract level. Other countries may have comparable national databases.

### 10.1.1. Population density

Description: Total population per land area where the tree is located.

### 10.1.2. Housing tenure (renter or owner occupied)

Description: Percentages of owner-occupied and renter-occupied properties where the tree is located.

### 10.1.3. Housing occupancy (occupied or vacant housing units)

Description: Percentage of occupied and vacant housing units where the tree is located.

### 10.1.4. Property values (median household value of owner-occupied units)

Description: Median property value where the tree is located.

### 10.1.5. Household income (median income in dollars)

Description: Median household income where the tree is located.

### 10.1.6. Educational attainment

Description: Percentages of population that has attained a particular level of education (e.g., high school diploma, college degree) where the tree is located.

## 10.2. Local Data

### 10.2.1. Crime data

Description: Crime rates for geographic area near the tree (e.g., assaults, drug possession). See, for example, Kondo et al. (2017).

### 10.2.2. Health data

Description: Rates of health issues for the geographic area near the tree (e.g., asthma, heart disease).

### 10.2.3. Local demographic data

Description: Other demographic data specific to the community that may not be available at the national level.

## 10.3. Community Surveys and Interviews

Surveys and interviews of those who receive trees through planting initiatives, as well as others who plant, maintain, and manage trees, can help in understanding how urban forests change over time. As with other components of the Community Data Set, we strongly recommend collaborating with researchers to collect these data. See, for example, surveys of residents and urban greening programs in Moskell and Allred (2013), Locke et al. (2015), Conway (2016), Svendsen et al. (2016), and Breger et al. (2019). Community surveys and interviews could collect, for example, household-level sociodemographic or consumer lifestyle data, resident perceptions of trees, and neighborhood histories.

## 11. Acknowledgments

Many individuals contributed to this Resource Guide. Current and former colleagues from the UTGL working group helped to refine the protocols and suggested material to include in this Resource Guide: Julia Bartens, David Bienemann, Michele Bigger, Cindy Blain, Jerry Bond, Chad Clink, Dana Dentice, Anne Fenkner, Burney Fischer, Jason Grabosky, Jennifer Karp, Emily King, Jackie Lu, Jessica Sanders, Phil Silva, Nancy Sonti, Emily Spillett, Matthew Stephens, Erika Teach, Doug Wildman, and Ruth Williams. We are indebted to their contributions to this project. We are also grateful to the attendees of the first UTGL symposium at The Morton Arboretum in 2011 and to the respondents to the survey of practitioner-driven monitoring projects (Roman et al. 2013) for inspiring us to produce these protocols and associated resources, and to the citizen scientists who pilot tested the Field Guide (Roman et al. 2017). At The Nature Conservancy, we thank Bill Toomey and Rachel Holmes for collaborating with training field interns carrying out these protocols through the Healthy Trees, Healthy Cities initiative; that experience helped us to further refine the field methods and resources. We also thank Lindsay Shafer for her contributions to translating the Minimum Data Set into a user-friendly field guide, as part of her master's degree at the University of Pennsylvania. We appreciate comments and critiques from colleagues who reviewed an earlier draft of this document: Mark Hatfield, Yasha Magarik, Eric North, Marin Palmer, and Sjana Schanning. Funding for producing the Resource Guide was provided by the USDA Forest Service State and Private Forestry, Urban and Community Forestry program. Funding for the pilot test of the protocols was provided by the Forest Service, Northern Research Station, Philadelphia Field Station, and The Morton Arboretum.

---

## **Part III: Supporting Documentation**

---

## Literature Cited

- American Nursery & Landscape Association. 2004. **American standard for nursery stock**. Indiana Department of Natural Resources, Division of Forestry. Columbus, OH: ANSI Z60.1-2004.
- Ames, B.; Dewald, S. 2003. **Working proactively with developers to preserve urban trees**. *Cities*. 20(2): 95–100.
- Anderson, J.R.; Hardy, E.E.; Roach, J.T.; Witmer, R.E. 1976. **A land use and land cover classification system for use with remote sensor data**. Professional Paper 964. Alexandria, VA: U.S. Department of the Interior, Geological Survey. 28 p.
- Arbor Day Foundation. 2018. **The Arbor Day Foundation’s energy-saving trees and community canopy programs launch spring project season**. Press Release April 20, 2018 (accessed 7 October 2018).
- Avery, T.; Burkhart, H. 2001. **Forest measurements**. 5th ed. Boston, MA: McGraw-Hill Book Company. 456 p.
- Banks, N.; North, E.A.; Johnson, G.R. 2018. **An analysis of agreement between volunteer- and researcher-collected urban tree inventory data**. *Arboriculture & Urban Forestry*. 44: 73–86.
- Barger, C.T.; Moorhead, D.J. 2007. **EDDMapS—early detection and distribution mapping system for the southeast exotic pest plant council**. *Wildwood Weeds*. Fall 2007: 4–8.
- Barnard, E. 2002. **New York City trees**. New York, NY: Columbia University Press. 240 p.
- Barnard, E.; Meyer, P.; Bringer, C. 2017. **Philadelphia trees: a field guide to the city and the surrounding Delaware Valley**. New York, NY: Columbia University Press. 280 p.
- Bernhardt, E.; Swiecki, T.J. 1991. **Guidelines for developing and evaluating tree ordinances**. Unpublished report to Urban Forestry Program, California Department of Forestry and Fire Protection, Sacramento, CA. 76 p.
- Bird, W.J. 2014. **Worcester Tree Initiative celebrates 30,000 trees planted**. *Worcester Magazine*. <http://worcestermag.com/2014/10/06/worcester-tree-initiative-celebrates-30000-trees-planted/27824> (accessed 24 October 2015).

- Blair, S.A.; Koeser, A.K.; Knox, G.W.; Roman, L.A.; Thetford, M. 2019. **Visual health assessments for palms.** *Urban Forestry & Urban Greening*. 41: 195-200.
- Bloniarz, D.V.; Ryan, H.D.P., III. 1996. **The use of volunteer initiatives in conducting urban forest resource inventories.** *Journal of Arboriculture*. 22(2): 75–82.
- Blood, A.; Starr, G.; Escobedo, F.J.; Chappelka, A.; Wiseman, P.E.; Sivakumar, R.; Staudhammer, C.L. 2016. **Resolving uncertainties in predictive equations for urban tree crown characteristics of the southeastern United States: local and general equations for common and widespread species.** *Urban Forestry & Urban Greening*. 20: 282–294.
- Bond, J. 2010. **Tree condition: health.** *Arborist News*. 19(1): 35–38.
- Bond, J. 2012. **Urban tree health: a practical and precise estimation method.** Geneva, NY: Urban Forest Analytics. 107 p.
- Bond, J. 2013. **Best management practices—Tree inventories.** 2nd ed. 2013. Champaign, IL: International Society of Arboriculture. 35 p.
- Bowser, A.; Hansen, D.; Preece, J.; He, Y.; Boston, C.; Hammock, J. 2014. **Gamifying citizen science: a study of two user groups.** In: Proceedings of the companion publication of the 17th ACM conference on computer supported cooperative work and social computing. New York, NY: ACM New York: 137–140.
- Boyer, D.J.; Roman, L.A.; Henning, J.G.; McFarland, M.; Dentice, D.; Low, S.C.; Thomas, C.; Abrams, G. 2016. **Data management for urban tree monitoring—software requirements.** Philadelphia, PA: Azavea. 124 p. <http://www.azavea.com/research/urban-tree-monitoring> (accessed 18 April 2019).
- Brassel, P.; Lischke, H. 2001. **Swiss national forest inventory: methods and models of the second assessment.** Birmendorf, Switzerland. WSL Swiss Federal Research Institute.
- Breger, B.; Eisenman, T.E.; Kramer, M.; Roman, L.A.; Rogan, J.; Martin, D. 2019. **Urban tree survival and stewardship in a state-managed planting initiative: A case study in Holyoke, Massachusetts.** *Urban Forestry & Urban Greening*. 43: e126382.
- Briber, B.; Hutyra, L.; Reinmann, A.; Raciti, S.; Dearborn, V.; Holden, C.; Dunn, A. 2015. **Tree productivity enhanced with conversion from forest to urban land covers.** *PLoS ONE* 10(8): e0136237.
- Brokaw, N.; Thompson, J. 2000. **The H for DBH.** *Forest Ecology & Management*. 129: 89–91.
- Broman, K.W.; Woo, K.H. 2018. **Data organization in spreadsheets.** *The American Statistician*. 72(1): 2–10.

- Campbell, L.K.; Svendsen, E.S.; Roman, L.A. 2016. **Co-production of knowledge at the research-practice interface: case studies from urban forestry.** *Journal of Environmental Management.* 57: 1262–1280.
- Cadenasso, M. 2017. **Personal communication.** Professor, University of California, Davis, One Shields Avenue, Davis, CA 95616.
- Celestian, S.B.; Martin, C.A. 2005. **Effects of parking lot location on size and physiology of four southwestern U.S. landscape trees.** *Journal of Arboriculture.* 31: 191–197.
- Centers for Disease Control and Prevention, National Institute for Occupational Safety and Health [CDCP NIOSH]. [N.d. a]. **Heat stress—heat related illness.** <https://www.cdc.gov/niosh/topics/heatstress/heatrelillness.html> (accessed 7 August 2018).
- Centers for Disease Control and Prevention, National Institute for Occupational Safety and Health [CDCP NIOSH]. [N.d. b]. **Motor vehicle safety at work.** <https://www.cdc.gov/niosh/motorvehicle/default.html> (accessed 7 August 2018).
- Choukas-Bradley, M. 2008. **City of trees: the complete field guide to the trees of Washington, DC.** Baltimore, MD: Johns Hopkins University Press. 368 p.
- Citizenscience.gov. 2016. **Federal crowdsourcing and citizen science toolkit.** <https://crowdsourcing-toolkit.sites.usa.gov/> (accessed 2 August 2017).
- Clark, J.R.; Matheny, N.P.; Cross, G.; Wake, V. 1997. **A model of urban forest sustainability.** *Journal of Arboriculture.* 23: 17–30.
- Climate Action Reserve. 2018. **Urban forest project.** <http://www.climateactionreserve.org/urban-forest-project/> (accessed 2 August 2018).
- Condit, R. 1998. **Tropical forest census plots.** Berlin, Heidelberg and New York, NY: Springer-Verlag.
- Conway, T.M. 2016. **Tending their urban forest: Residents' motivations for tree planting and removal.** *Urban Forestry & Urban Greening.* 17: 23–32.
- Cozad, S. 2005. **STRATUM case study evaluation in Minneapolis, Minnesota.** Davis, CA: University of California, Davis. 81 p. M.S. thesis.
- Crall, A.W.; Newman, G.J.; Stohlgren, T.J.; Holfelder, K.A.; Graham, J.; Waller, D.M. 2011. **Assessing citizen science data quality: an invasive species case study.** *Conservation Letters.* 4: 433–442.
- Crown, C.A.; Greer, B.Z.; Gift, D.M.; Watt, F.S. 2018. **Every tree counts: reflections on NYC's third volunteer street tree inventory.** *Arboriculture & Urban Forestry.* 44: 49–58.

- Cumming, A.B.; Nowak, D.J.; Twardus, D.B.; Hoehn, R.; Mielke, M.; Rideout, R. 2007. **Urban forests of Wisconsin: pilot monitoring project 2002**. NA-FR-05-07. Newtown Square, PA: U.S. Department of Agriculture, Forest Service, Northeastern Area State and Private Forestry. 33 p.
- Cumming, A.B.; Twardus, D.B.; Nowak, D.J. 2008. **Urban forest health monitoring: large-scale assessments in the United States**. *Arboriculture & Urban Forestry*. 34: 341–346.
- Day, L.; Smoke, T. 2011. **Field guide to the street trees of New York City**. Baltimore, MD: John Hopkins University Press. 296 p.
- di Salvo, A. 2016. **Personal communication**. Outreach and science supervisor, Urban Forestry, Portland Parks & Recreation. 10910 N Denver Avenue, Portland, OR 97217.
- Dickinson, J.L.; Shirk, J.; Bonter, D.; Bonney, R.; Crain, R.L.; Martin, J.; Phillips, T.; Purcell, K. 2012. **The current state of citizen science as a tool for ecological research and public engagement**. *Frontiers in Ecology & Evolution*. 10: 291–297.
- Dickinson, J.L.; Zuckerberg, B.; Bonter, D.N. 2010. **Citizen science as an ecological research tool: challenges and benefits**. *Annual Review of Ecology, Evolution, & Systematics*. 41: 149–172.
- Dyson, K.; Ziter, C.; Fuentes, T.L.; Patterson, M.S. 2019. **Conducting urban ecology research on private property: advice for new urban ecologists**. *Journal of Urban Ecology*. 5(1): juz001.
- Ellis, B. 2015. **Chesapeake gardening and landscaping: the essential green guide**. Chapel Hill, NC: University of North Carolina. 315 p.
- Elmes, A.; Rogan, J.; Roman, L.A.; Williams, C.; Ratick, S.; Nowak, D.; Martin, D. 2018. **Predictors of mortality for juvenile trees in a residential urban-to-rural cohort in Worcester, MA**. *Urban Forestry & Urban Greening*. 30: 138–151.
- Gerhold, H.D. 2007a. **Callery pear cultivars tested as street trees: final report on a 12-year study**. *Arboriculture & Urban Forestry*. 33: 153–156.
- Gerhold, H.D. 2007b. **Crabapple cultivars tested as street trees: third report**. *Arboriculture & Urban Forestry*. 33: 176–181.
- Gerhold, H.D. 2008. **Serviceberry cultivars tested as street trees: second report**. *Arboriculture & Urban Forestry*. 34: 129–132.
- Goldman, E. 2017. **Seeing community through the trees: characterizing resident response to urban-tree planting initiatives**. International Development, Community and Environment. Worcester, MA: Clark University. 121 p. M.A. thesis.

- Gschwanter, T.; Schadauer, K.; Vidal, C.; Lanz, A.; Tomppo, E.; di Cosmo, L.; Robert, N.; Duursma, D.E.; Lawrence, M. 2009. **Common tree definitions for national forest inventories in Europe**. *Silva Fennica*. 43: 303–321.
- Hallett, R.A.; Bailey, S.W.; Horsley, S.B.; Robert, P. 2006. **Influence of nutrition and stress on sugar maple at a regional scale**. *Canadian Journal of Forest Research*. 36: 2235–2246.
- Hallett, R.A.; Hallett, T. 2018. **Citizen science and tree health assessment: How useful are the data?** *Arboriculture & Urban Forestry*. 44: 236–247.
- Hallett, R.A.; Johnson, M.L.; Sonti, N.F. 2018. **Assessing the tree health impacts of salt water flooding in coastal cities: a case study in New York City**. *Landscape and Urban Planning*. 177: 171–177.
- Hamilton, K.; Koeser, A.K.; Landry, S.M. 2018. **Accuracy of volunteer-derived data from a single-day inventory event built around a crowd-sourcing tree mapping application**. *Arboriculture & Urban Forestry*. 44: 248–254.
- Harrington, J.L. 2009. **Relational database design and implementation: Clearly explained**. 3rd ed. Burlington, MA: Morgan Kaufmann. 419 p.
- Harris, R.W.; Clark, J.R.; Matheny, N.P. 2004. **Arboriculture: integrated management of landscape trees, shrubs, and vines**. 4th ed. Upper Saddle River, NJ: Prentice Hall. 578 p.
- Hatch, C.; Faber, P. 2007. **Trees of the California landscape: a photographic manual of native and ornamental trees**. Berkeley, CA: University of California Press. 544 p.
- Hauer, R.J.; Peterson, W.D. 2016. **Municipal tree care and management in the United States: a 2014 urban & community forestry census of tree activities**. Special Publication 16-1. Madison, WI: College of Natural Resources, University of Wisconsin—Stevens Point. 71 p.
- Hernandez, M.J. 2013. **Database design for mere mortals: a hands-on guide to relational database design**. 3rd ed. Upper Saddle River, NJ: Addison-Wesley. 613 p.
- Hilbert, D.R.; Roman, L.A.; Koeser, A.K.; van Doorn, N.S. 2019. **Factors associated with urban tree mortality: a literature review**. *Arboriculture & Urban Forestry*. 45(5): 167–200.
- Holt, L. 2010. **Sticky trees: learn to recognize at a glance the 15 most common trees in the United States—in just one hour, guaranteed**. New York, NY: Laurence Holt Books. 256 p.
- Hostetler, A.E.; Rogan, J.; Martin, D.G.; DeLauer, V.; O’Neil-Dunne, J. 2013. **Characterizing tree canopy loss using multi-source GIS data in Central Massachusetts, USA**. *Remote Sensing Letters*. 4: 1137–1146.

- Husch, B.; Beers, T.W.; Kershaw, J.A., Jr. 2002. **Forest mensuration**. New York, NY: John Wiley & Sons. 443 p.
- i-Tree. 2017a. **i-Tree Eco field guide, ver. 6.0**. April 16, 2017. Washington, DC: U.S. Department of Agriculture, Forest Service and Kent, OH: Davey Tree Expert Co., and other cooperators. 45 p. Available at <https://www.itreetools.org> (accessed July 11, 2017).
- i-Tree. 2017b. **i-Tree pest detection**. Washington, DC: U.S. Department of Agriculture, Forest Service and Kent, OH: Davey Tree Expert Co., and other cooperators. 45 p. Available at <https://www.itreetools.org/tools/i-tree-pest-detection-iped> (accessed 26 June 2020).
- Kitahara, F.; Mizoue, N.; Yoshida, S. 2009. **Evaluation of data quality in Japanese National Forest Inventory**. *Environmental Monitoring & Assessment*. 159: 331–340.
- Ko, Y.; Lee, J.H.; McPherson, E.G.; Roman, L.A. 2015a. **Factors affecting long-term mortality of residential shade trees: evidence from Sacramento, California**. *Urban Forestry & Urban Greening*. 14: 500–507.
- Ko, Y.; Lee, J.H.; McPherson, E.G.; Roman, L.A. 2015b. **Long-term monitoring of Sacramento shade program trees: tree survival, growth and energy-saving performance**. *Landscape and Urban Planning*. 143: 183–191.
- Koeser, A.K.; Gilman, E.F.; Paz, M.; Harchick, C. 2014. **Factors influencing urban tree planting program growth and survival in Florida, United States**. *Urban Forestry & Urban Greening*. 13: 655–661.
- Koeser, A.K.; Smiley, E.T. 2017. **Impact of assessor on tree risk assessment ratings and prescribed mitigation measures**. *Urban Forestry & Urban Greening*. 24: 109–115.
- Kondo, M.C.; Han, S.; Donovan, G.H.; MacDonald, J.M. 2017. **The association between urban trees and crime: evidence from the spread of emerald ash borer in Cincinnati**. *Landscape and Urban Planning*. 157: 193–199.
- Konijnendijk, C.C.; Ricard, R.M.; Kenney, A.; Randrup, T.B. 2006. **Defining urban forestry—A comparative perspective of North America and Europe**. *Urban Forestry & Urban Greening*. 4: 93–103.
- Kumar, N.; Belhumeur, P.N.; Biswas, A.; Jacobs, D.W.; Kress, W.J.; Lopez, I.C.; Soares, J.V.B. 2012. **Leafsnap: a computer vision system for automatic plant species identification**. *Proceedings of the 12th European conference on computer vision ECCV 2012*. Heidelberg, Germany: Springer-Verlag. 7573: 502–516. [https://doi.org/10.1007/978-3-642-33709-3\\_36](https://doi.org/10.1007/978-3-642-33709-3_36).

- Lambin, E.F.; Geist, H.; Rindfuss, R.R. 2006. **Introduction: local processes with global impacts.** In: Lambin, E.F.; Geist, H., eds. Land-use and land-cover change: local processes and global impacts. Berlin, Germany: Springer-Verlag: 1–8.
- Lamprecht, M.R.; Sabatini, D.M.; Carpenter, A.E. 2007. **CellProfiler<sup>TM</sup>: free, versatile software for automated biological image analysis.** *BioTechniques*. 42: 71–75.
- Larsen, G.A. 2011. **SQL server: natural key versus surrogate key.** Database Journal. Posted Jan. 31, 2011. [www.databasejournal.com/features/mssql/article.php/3922066/SQL-Server-Natural-Key-Verses-Surrogate-Key.htm](http://www.databasejournal.com/features/mssql/article.php/3922066/SQL-Server-Natural-Key-Verses-Surrogate-Key.htm) (accessed 18 April 2019).
- Lawrence, A.B.; Escobedo, F.J.; Staudhammer, C.L.; Zipperer, W. 2012. **Analyzing growth and mortality in a subtropical urban forest ecosystem.** *Landscape and Urban Planning*. 104: 85–94.
- Leers, M.; Moore, G.M.; May, P.B. 2018. **Assessment of six indicators of street tree establishment in Melbourne, Australia.** *Arboriculture & Urban Forestry*. 44: 12–22.
- Leff, M. 2016. **The sustainable urban forest: a step-by-step approach.** The Davey Institute and U.S. Department of Agriculture, Forest Service. [www.itreetools.org/resources/content/Sustainable\\_Urban\\_Forest\\_Guide\\_14Nov2016.pdf](http://www.itreetools.org/resources/content/Sustainable_Urban_Forest_Guide_14Nov2016.pdf) (accessed 9 December 2016).
- Leibowitz, R. 2012. **Urban tree growth and longevity: an international meeting and research symposium white paper.** *Arboriculture & Urban Forestry*. 38: 237–241.
- Levinsson, A.; Fransson, A-M.; Emilsson, T. 2017. **Investigating the relationship between various measuring methods for determination of establishment success of urban trees.** *Urban Forestry & Urban Greening*. 28: 21–27.
- Lima, J.M.T.; Staudhammer, C.L.; Brandeis, T.J.; Escobedo, F.J.; Zipperer, W. 2013. **Temporal dynamics of a subtropical urban forest in San Juan, Puerto Rico.** *Landscape and Urban Planning*. 120: 96–106.
- Lindenmayer, D.B.; Likens, G.E. 2010a. **The science and application of ecological monitoring.** *Biological Conservation*. 143: 1317–1328.
- Lindenmayer, D.B.; Likens, G.E. 2010b. **Effective ecological monitoring.** Washington, DC: CSIRO Publishing. 169 p.
- Lindsey, P.; Bassuk, N. L. 1991. **Specifying soil volumes to meet the water needs of mature urban street trees and trees in containers.** *Journal of Arboriculture*. 17(6): 141–149.
- Lindsey, P.; Bassuk, N.L. 1992. **Redesigning the urban forest from the ground below: a new approach to specifying adequate soil volumes for street trees.** *Journal of Arboriculture*. 24 (3): 25–39.

- Little, E. 1980a. **Audubon Society field guide to North American trees: Eastern region.** New York, NY: Alfred A Knopf. 716 p.
- Little, E. 1980b. **Audubon Society field guide to North American trees: Western region.** New York, NY: Alfred A Knopf. 640 p.
- Locke, D.H.; Roman, L.A.; Murphy-Dunning, C. 2015. **Why opt-in to a planting program? Long-term residents value street tree aesthetics.** *Arboriculture & Urban Forestry.* 41: 324–333.
- Loshin, D. 2011. **The practitioner's guide to data quality improvement.** Burlington, MA: Morgan Kaufmann. 397 p.
- Lu, J.W.T.; Svendsen, E.S.; Campbell, L.K.; Greenfield, J.; Branden, J.; King, K.L.; Falxa-Raymond, N. 2010. **Biological, social, and urban design factors affecting young street tree mortality in New York City.** *Cities and the Environment.* 3: article 5.
- Lund, H.G. 1999. **A 'forest' by any other name...** *Environmental Science & Policy.* 2: 125–133.
- MacDicken, K.G.; Wolf, G.V.; Briscoe, C.B. 1991. **Standard research methods for multipurpose trees and shrubs: Manual No. 5.** Arlington, VA: Winrock International Institute for Agricultural Development. 93 p.
- Magarik, Y.A.S.; Roman, L.A.; Henning, J.G. 2020. **How should we measure multi-stemmed urban trees?** *Urban Forestry & Urban Greening.* 47: e126481.
- Martin, M.P.; Simmons, C.; Ashton, M.S. 2016. **Survival is not enough: the effects of microclimate on growth and health of common urban tree species in San Francisco, California.** *Urban Forestry & Urban Greening.* 19: 1–6.
- McHale, M.; Burke, I.C.; Lefsky, M.; Peper, P.; McPherson, E.G. 2009. **Urban forest biomass estimates: Is it important to use allometric relationships developed specifically for urban trees?** *Urban Ecosystems.* 12(1): 95–113.
- McPherson, E.G. 2014. **Monitoring million trees LA: tree performance during the early years and future benefits.** *Arboriculture & Urban Forestry.* 40: 285–300.
- McPherson, E.G.; Albers, S.N. 2014. **Evaluation of seven drought tolerant tree species for central California.** *Western Arborist.* Fall: 10–15.
- McPherson, E.G.; Berry, A.; van Doorn, N.S. 2018. **Performance testing to identify climate-ready trees.** *Urban Forestry & Urban Greening.* 29: 28–39.
- McPherson, E.G.; Kotow, L. 2013. **A municipal forest report card: results for California, USA.** *Urban Forestry & Urban Greening.* 12: 134–143.

- McPherson, E.G.; Muchnick, J. 2005. **Effects of street tree shade on asphalt concrete pavement performance.** *Journal of Arboriculture*. 31(6): 303–310.
- McPherson, E.G.; Simpson, J.R.; Peper, P.J.; Maco, S.E.; Xiao, Q. 2005. **Municipal forest benefits and costs in five US cities.** *Journal of Forestry*. 103(8): 411–416.
- McPherson, E.G.; Simpson, J.R.; Xiao, Q.; Wu, C. 2008. **Los Angeles 1-million tree canopy cover assessment.** Gen. Tech. Rep. PSW-GTR-207. Albany, CA: U.S. Department of Agriculture, Forest Service, Pacific Southwest Research Station. 52 p.
- McPherson, E.G.; van Doorn, N.S.; Peper, P.J. 2016. **Urban tree database and allometric equations.** Gen. Tech. Rep. PSW-GTR-253. Albany, CA: U.S. Department of Agriculture, Forest Service, Pacific Southwest Research Station. 86 p.
- McPherson, E.G.; Xiao, Q.; Purohit, J.; Diitenberger, M.; Boardman, C.R.; Simpson, J.; Peper, P. 2014. **ecoSmart landscapes: a versatile SaaS platform for green infrastructure applications in urban environments.** Misc. publ. In: Ames, D.P.; Quinn, N.W.T.; Rizzoli, A.E., eds. 7th international congress on Environmental Modeling and Software. San Diego, CA: International Environmental Modelling and Software Society: 1017–1024.
- McRoberts, R.E.; Bechtold, W.A.; Patterson, P.L.; Scott, C.T.; Reams, G.A. 2005. **The enhanced Forest Inventory and Analysis program of the USDA Forest Service: historical perspective and announcement of statistical documentation.** *Journal of Forestry*. 103: 305–308.
- Metropolitan Transportation Commission [MTC]. 1986. **Pavement condition index distress identification manual for asphalt and surface treatment pavements.** Second ed. Oakland, CA. 35 p.
- Millers, I.; Lachange, D.; Burkman, W.G.; Allen, D.C. 1991. **North American sugar maple decline project: organization and field methods.** Gen. Tech. Rep. NE-154. Radnor, PA: U.S. Department of Agriculture, Forest Service, Northeastern Forest Experiment Station. 26 p.
- Mincey, S.K.; Hutten, M.; Fischer, B.C.; Evans, T.P.; Stewart, S.I.; Vogt, J.M. 2013. **Structuring institutional analysis for urban ecosystems: a key to sustainable urban forest management.** *Urban Ecosystems*. 16: 553–571.
- Mincey, S.K.; Vogt, J.M. 2014. **Watering strategy, collective action, and neighborhood-planted trees: a case study of Indianapolis, Indiana.** *Arboriculture & Urban Forestry*. 40: 84–95.

- Morani, A.; Nowak, D.J.; Hirabayashi, S.; Calfapietra, C. 2011. **How to select the best tree planting locations to enhance air pollution removal in the MillionTreesNYC initiative.** *Environmental Pollution*. 159: 1040–1047.
- Moskell, C.; Allred, S.B. 2013. **Residents' beliefs about responsibility for the stewardship of park trees and street trees in New York City.** *Landscape & Urban Planning*. 120: 85–95.
- National Weather Service [NWS]. [N.d.]. **Heat safety tips and resources.** <https://www.weather.gov/safety/heat> (accessed 7 August 2018).
- National Wildfire Coordinating Group [NWCG]. [N.d.]. **Heat illness prevention (HIP) pocket guide.** <http://www.oregon.gov/ODF/Documents/Fire/HRIPocketGuide.pdf> (accessed 7 August 2018).
- Nguyen, V.D.; Roman, L.A.; Locke, D.H.; Mincey, S.K.; Sanders, J.R.; Smith Fichman, E.; Duran-Mitchell, M.; Tobing, S.L. 2017. **Branching out to residential lands: missions and strategies of five tree distribution programs in the U.S.** *Urban Forestry & Urban Greening*. 22: 24–35.
- Nowak, D.J.; Bodine, A.R.; Hoehne, R.E., III; Edgar, C.B.; Hartel, D.R.; Lister, T.W.; Brandeis, T.J. 2016a. **Austin's urban forest, 2014.** *Resour. Bull. NRS-100*. Newtown Square, PA: U.S. Department of Agriculture, Forest Service, Northern Research Station. 55 p.
- Nowak, D.J.; Bodine, A.R.; Hoehn, R.E., III; Ellis, A.E.; Low, S.C.; Roman, L.A.; Henning, J.G.; Stephan, E.; Taggart, T.; Endreny, T. 2016b. **The urban forests of Philadelphia.** *Resour. Bull. NRS-106*. Newtown Square, PA: U.S. Department of Agriculture, Forest Service, Northern Research Station. 80 p.
- Nowak, D.J.; Crane, D.E.; Stevens, J.C.; Hoehn, R.E.; Walton, J.T.; Bond, J. 2008. **A ground-based method of assessing urban forest structure and ecosystem services.** *Arboriculture & Urban Forestry*. 34: 347–358.
- Nowak, D.J.; Hoehne, R.E., III; Bodine, A.R.; Crane, D.E.; Dwyer, J.F.; Bonnewell, V.; Watson, G. 2013a. **Urban trees and forests of the Chicago region.** *Resour. Bull. NRS-84*. Newtown Square, PA: U.S. Department of Agriculture, Forest Service, Northern Research Station. 106 p.
- Nowak, D.J.; Hoehn, R.E.; Bodine, A.R.; Greenfield, E.J.; O'Neil-Dunne, J. 2013b. **Urban forest structure, ecosystem services and change in Syracuse, NY.** *Urban Ecosystems*. 19: 1455–1477.
- Nowak, D.J.; Kuroda, M.; Crane, D.E. 2004. **Tree mortality rates and population projections in Baltimore, MD: USA.** *Urban Forestry & Urban Greening*. 2: 139–147.

- Nowak, D.J.; Stein, S.M.; Randler, P.B.; Greenfield, E.J.; Comas, S.J.; Carr, M.A.; Alig, R.J. 2010. **Sustaining America's urban trees and forests: a forests on the edge report.** Gen. Tech. Rep. NRS-62. Newtown Square, PA: U.S. Department of Agriculture, Forest Service, Northern Research Station. 27 p.
- Östberg, J.; Delshammar, T.; Nielsen, A.B. 2012. **Standards for conducting tree inventories in urban environments.** Version 1.0. Uppsala, Sweden. Swedish University of Agricultural Sciences, Department of Landscape Architecture, Planning and Management. 49 p.
- Östberg, J.; Delshammar, T.; Wiström, B.; Nielsen, A.B. 2013. **Grading of parameters for urban tree inventories by city officials, arborists, and academics using the Delphi method.** *Environmental Management*. 51: 694–708.
- Oswalt, S.N.; Smith, W.B.; Miles, P.D.; Pugh, S.A. 2014. **Forest resources of the United States, 2012: a technical document supporting the Forest Service 2010 update of the RPA assessment.** Gen. Tech. Rep. WO-91. Washington, DC: U.S. Department of Agriculture, Forest Service. 218 p.
- PA Urban & Community Forestry Council. 2018. **Urban Tree Monitoring Training Toolkit: Train citizen scientists to monitor recently planted tree performance.** <https://treepennsylvania.org/young-urban-tree-monitoring-training-toolkit/> (accessed 1 October 2018).
- Piana, M.; Troxel, B. 2014. **Beyond planting: An urban forestry primer. Scenario 4: building the urban forest.** <https://scenariojournal.com/article/beyond-planting/> (accessed 21 November 2017).
- Plotnik, A. 2000. **The urban tree book: an uncommon field guide for city and town.** New York, NY: Three Rivers Press. 433 p.
- Pokorny, J.D. 2003. **Urban tree risk management: a community guide to program design and implementation.** NA-TP-03-03. St. Paul, MN: U.S. Department of Agriculture, Forest Service, Northeastern Area. 194 p.
- Pontius, J.; Hallett, R. 2014. **Comprehensive methods for earlier detection and monitoring of forest decline.** *Forest Science*. 60: 1156–1163.
- Powell, D.C. 1999. **Suggested stocking levels for forest stands in northeastern Oregon and southeastern Washington: an implementation guide for the Umatilla National Forest.** Tech. Publ. F14-SO-TP-03-99. Walla Walla, WA: U.S. Department of Agriculture, Forest Service, Pacific Northwest Region, Umatilla National Forest. 300 p.
- Pregitzer, C.C.; Charlop-Powers, S.; Bibbo, S.; Forgione, H.M.; Gunther, B.; Hallett, R.A.; Bradford, M.A. 2018. **A city-scale assessment reveals that native forest types and overstory species dominate New York City forests.** *Ecological Applications*. 29: e01819.

- R Core Team. 2017. **R: A language and environment for statistical computing**. Vienna, Austria: R Foundation for Statistical Computing.
- Richards, N.A. 1979. **Modeling survival and consequent replacement needs of a street tree population**. *Journal of Arboriculture*. 5: 251–255.
- Richards, N.A. 1992. **Optimum stocking of urban trees**. *Journal of Arboriculture*. 18: 64–68.
- Ritter, M. 2011. **A Californian's guide to the trees among us**. Berkeley, CA: Heydey. 192 p.
- Roman, L.A.; Battles, J.J.; McBride, J.R. 2014a. **Determinants of establishment survival for residential trees in Sacramento County, CA**. *Landscape and Urban Planning*. 129: 22–31.
- Roman, L.A.; Battles, J.J.; McBride, J.R. 2014b. **The balance of planting and mortality in a street tree population**. *Urban Ecosystems*. 17: 387–404.
- Roman, L.A.; Battles, J.J.; McBride, J.R. 2016. **Urban tree mortality: a primer on demographic approaches**. Gen. Tech. Rep. NRS-158. Newtown Square, PA: U.S. Department of Agriculture, Forest Service, Northern Research Station. 24 p.
- Roman, L.A.; Campbell, L.K.; Jordan, R.C. 2018a. **Civic science in urban forestry: an introduction**. *Arboriculture & Urban Forestry*. 44: 41–48.
- Roman, L.A.; McPherson, E.G.; Scharenbroch, B.C.; Bartens, J. 2013. **Identifying common practices and challenges for local urban tree monitoring programs across the United States**. *Arboriculture & Urban Forestry*. 39: 292–299.
- Roman, L.A.; Scharenbroch, B.C.; Östberg, J.P.A.; Mueller, L.S.; Henning, J.G.; Koeser, A.K.; Sanders, J.R.; Betz, D.R.; Jordan, R.C. 2017. **Data quality in citizen science urban tree inventories**. *Urban Forestry & Urban Greening*. 22: 124–135.
- Roman, L.A.; Smith, B.C.; Dentice, D.; Maslin, M.; Abrams, G. 2018b. **Monitoring young tree survival with citizen scientists: the evolving Tree Checkers program in Philadelphia, PA**. *Arboriculture & Urban Forestry*. 44: 255–265.
- Roman, L.A.; van Doorn, N.S.; McPherson, E.G.; Scharenbroch, B.C.; Henning, J.G. [et al.]. 2020. **Urban tree monitoring: A field guide**. Gen. Tech. Rep. NRS-194. Madison, WI: U.S. Department of Agriculture, Forest Service, Northern Research Station. 48 p. <https://doi.org/10.2737/NRS-GTR-194>.
- Roman, L.A.; Walker, L.A.; Martineau, C.M.; Muffly, D.J.; MacQueen, S.A.; Harris, W. 2015. **Stewardship matters: case studies in establishment success of urban trees**. *Urban Forestry & Urban Greening*. 14: 1174–1182.

- Rushforth, K.; Tomblin, G. 2004. **The easy tree guide: common native and cultivated trees of the United States and Canada.** Guilford, CO: Falcon Guide. 288 p.
- Sanders, J.R.; Grabosky, J.C. 2014. **20 years later: Does reduced soil area change overall tree growth?** *Urban Forestry & Urban Greening*. 13: 295–303.
- Scharenbroch, B.C.; Catania, M. 2012. **Soil quality attributes as indicators of urban tree performance.** *Arboriculture and Urban Forestry*. 38: 214–228.
- Scharenbroch, B.C.; Carter, D.; Bialecki, M.; Fahey, R.; Scheberl, L. [et al.]. 2017. **A rapid urban site index for assessing the quality of street tree planting sites.** *Urban Forestry & Urban Greening*. 27: 279–286.
- Scharenbroch, B.E.; Fite, K.; Kramer, E.; Uhlig, R. 2018. **Pedogenic processes and urban tree health in engineered urban soils in Boston, Massachusetts, USA.** *Soil Science*. 183: 159–167.
- Scharenbroch, B.C.; Lloyd, J.E.; Johnson-Maynard, J.L. 2005. **Distinguishing urban soils with physical, chemical, and biological properties.** *Pedobiologia*. 49: 283–296.
- Scharenbroch, B.C.; Roman, L.A.; McPherson, E.G.; Bartens, J.; Boyer, D. 2014. **Taking the urban forest's pulse: working group focused on tree growth and longevity.** *Arborist News*. 23: 54–55.
- Sheil, D. 1995. **A critique of permanent plot methods and analysis with examples from Budongo Forest, Uganda.** *Forest Ecology and Management*. 77: 11–34.
- Silberschatz, A.; Korth, H.F.; Sudarshan, S. 2011. **Database systems concepts.** 6th ed. New York, NY: McGraw Hill. 1349 p.
- Silva, P.; Barry, E.; Plitt, S. 2013. **TreeKIT: measuring, mapping, and collaboratively managing urban forests.** *Cities and the Environment*. 6(1): article 3.
- Silvertown, J. 2009. **A new dawn for citizen science.** *Trends in Ecology and Evolution*. 24: 467–471.
- Sjöman, H.; Östberg, J.; Bühler, O. 2012. **Diversity and distribution of the urban tree population in ten major Nordic countries.** *Urban Forestry & Urban Greening*. 11: 31–39.
- Snowdon, P.; Raison, J.; Keith, H.; Ritson, P.; Grierson, P.; Adams, M.; Montagu, K.; Bi, H.; Burrows, W.; Eamus, D. 2002. **Protocol for sampling tree and stand biomass.** Technical Report 31. Canberra, Australia: Australian Greenhouse Office, National Carbon Accounting System.

- Staudhammer, C.; Escobedo, F.; Lawrence, A.; Duryea, M.; Smith, P.; Merritt, M. 2011. **Rapid assessment of change and hurricane impacts to Houston's urban forest structure.** *Arboriculture & Urban Forestry*. 37: 60–66.
- Steinman, J. 1998. **Tracking the health of trees over time on forest health monitoring plots.** In: Integrated tools for natural resources inventories in the 21st century. Gen. Tech. Rep. NC-212. St. Paul, MN: U.S. Department of Agriculture, Forest Service, North Central Forest Experiment Station: 334-339.
- Stewart, J.L.; Dundson, A.J. 1994. **Performance of 25 Central American dry zone hardwoods in a pantropical series of species elimination trials.** *Forest Ecology & Management*. 65: 183–193.
- Stewart, J.L.; Salazar, R. 1992. **A review of measurement options for multipurpose trees.** *Agroforestry Systems*. 19: 173–183.
- St. John, N. 2011. **Street tree inventories being conducted in five Portland neighborhoods.** *Neighborhood Notes*, June 29, 2011. [www.neighborhoodnotes.com/news/2011/06/street\\_tree\\_inventories\\_being\\_conducted\\_in\\_five\\_portland\\_neighborhoods/](http://www.neighborhoodnotes.com/news/2011/06/street_tree_inventories_being_conducted_in_five_portland_neighborhoods/) (accessed 9 December 2019).
- Straley, G. 1992. **Trees of Vancouver.** Vancouver, BC: University of British Columbia Press. 270 p.
- Svendsen, E.S.; Campbell, L.K.; Fisher, D.R.; Connolly, J.T.; Johnson, M.L. [et al.]. 2016. **Stewardship mapping and assessment project: A framework for understanding community-based environmental stewardship.** Gen. Tech. Rep. NRS-156. Newtown Square, PA: U.S. Department of Agriculture, Forest Service, Northern Research Station. 134 p.
- The Institute for Local Government. 2010. **Understanding the basics of land use and planning: glossary of land use and planning terms.** [https://www.ca-ilg.org/sites/main/files/file-attachments/2010\\_-\\_landuseglossary.pdf](https://www.ca-ilg.org/sites/main/files/file-attachments/2010_-_landuseglossary.pdf) (accessed 16 May 2019).
- Tracey, D. 2016. **Vancouver tree book: a living city field guide.** Vancouver, BC: Pure Wave Media. 240 p.
- Troxel, B.; Piana, M.; Ashton, M.S.; Murphy-Dunning, C. 2013. **Relationships between bole and crown size for young urban trees in the northeastern USA.** *Urban Forestry & Urban Greening*. 12(2): 144–153.
- Tulloch, A.I.T.; Possingham, H.P.; Joseph, L.N.; Szabo, J.; Martin, T.G. 2013. **Realising the full potential of citizen science monitoring programs.** *Biological Conservation*. 165: 128–138.

- Urban, J. 1992. **Bringing order to the technical dysfunction within the urban forest.** *Journal of Arboriculture*. 18(2): 85–90.
- Urban, J. 2008. **Up by roots: healthy soils and trees in the built environment.** Champaign, IL: International Society of Arboriculture. 479 p.
- USDA Forest Service [USDA FS]. 2014. **Urban forest inventory: monitoring the trees where people live.** Northern Research Station. <https://www.fs.fed.us/nrs/local-resources/docs/FIA-BrochureUrban14JUL.pdf> (accessed 27 November 2017).
- USDA Forest Service [USDA FS]. 2015. **Urban forest inventory and analysis: frequently asked questions.** Revised September 8, 2015. [www.fs.fed.us/research/docs/urban/urban-fia-faq](http://www.fs.fed.us/research/docs/urban/urban-fia-faq) (accessed 27 November 2017).
- USDA Forest Service [USDA FS]. 2016. **Forest Inventory and Analysis national core field guide. Volume 1: Field data collection procedures for Phase 2 plots, version 7.1.** Washington, DC. 432 p. [https://www.fia.fs.fed.us/library/field-guides-methods-proc/docs/2016/core\\_ver7-1\\_10\\_2016-opt.pdf](https://www.fia.fs.fed.us/library/field-guides-methods-proc/docs/2016/core_ver7-1_10_2016-opt.pdf) (accessed 1 August 2017).
- USDA Forest Service [USDA FS]. 2017. **Forest Inventory and Analysis national urban FIA plot field guide: field data collection procedures for urban FIA plots, version 7.1.** Washington, DC. 324 p. [https://www.fia.fs.fed.us/library/field-guides-methods-proc/docs/2016/core\\_ver7-1\\_10\\_2016-opt.pdf](https://www.fia.fs.fed.us/library/field-guides-methods-proc/docs/2016/core_ver7-1_10_2016-opt.pdf) (accessed 11 July 2017).
- USDA Forest Service [USDA FS]. 2020. **Forest Inventory and Analysis National Program Urban FIA Programs.** <https://www.fia.fs.fed.us/program-features/urban/> (accessed 1 July 2020).
- U.S. Department of Labor, Occupational Safety and Health Administration [USDL OSHA]. [N.d.]. **Personal protective equipment.** [https://www.osha.gov/SLTC/personalprotectiveequipment/hazards\\_solutions.html](https://www.osha.gov/SLTC/personalprotectiveequipment/hazards_solutions.html) (accessed 8 August 2017).
- U.S. Department of Transportation, Federal Highway Administration [USDA FHA]. [N.d.]. **Flexibility in highway design.** 193 p. <https://www.fhwa.dot.gov/environment/publications/flexibility/flexibility.pdf> (accessed 1 August 2017).
- van Doorn, N.S. 2014. **Best practices and quantified error rates for long-term tagged-tree inventories: examples from a temperate forest.** In: *Patterns and processes of forest growth: the role of neighborhood dynamics and tree demography in a northern hardwood forest*. Berkeley, CA: University of California, Berkeley: 90–123. Ph.D. dissertation. Chapter 3.

- van Doorn, N.S.; Battles, J.J.; Fahey, T.J.; Siccama, T.G.; Schwarz, P.A. 2011. **Links between biomass and tree demography in a northern hardwood forest: a decade of stability and change in Hubbard Brook Valley, New Hampshire.** Canadian Journal of Forest Research. 41: 1369–1379.
- van Doorn, N.S.; McPherson, E.G. 2018. **Demographic trends in Claremont California’s street tree populations.** Urban Forestry & Urban Greening. 29: 200–211.
- Van Laar, A.; Akca, A. 2007. **Forest mensuration.** Berlin, Germany: Springer. 385 p.
- Van Mantgem, P.J.; Stephenson, N.L. 2005. **The accuracy of matrix population model projections for coniferous trees in the Sierra Nevada, California.** Journal of Ecology. 93(4): 737-747.
- Vogt, J.M.; Fischer, B.C. 2014. **A protocol for citizen science monitoring of recently-planted urban trees.** Cities and the Environment. 7(2): article 4.
- Vogt, J.M.; Watkins, S.L.; Mincey, S.K.; Patterson, M.S.; Fischer, B.C. 2015a. **Explaining planted-tree survival and growth in urban neighborhoods: social-ecological approach to studying recently-planted trees in Indianapolis.** Landscape & Urban Planning. 136: 130–143.
- Vogt, J.; Watkins, S.L.; Widney, S.; Fischer, B. 2015b. **The need to standardize at-planting data.** Arborist News. 24(6): 27–31.
- Ward, R.C.; Loftis, J.C.; McBride, G.B. 1986. **The “data-rich but information-poor” syndrome in water quality monitoring.** Environmental Management. 10: 291–297.
- West, P.W. 2009. **Tree and forest measurement.** 2nd ed. Berlin, Germany: Springer-Verlag. 192 p.
- Westfall, J.A.; Woodall, C.W. 2007. **Measurement repeatability of a large-scale inventory of forest fuels.** Forest Ecology & Management. 253: 171–176.
- Widney, S.; Fischer, B.C.; Vogt, J. 2016. **Tree mortality undercuts ability of tree-planting programs to provide benefits: results of a three-city study.** Forests. 7: 65.
- Yang, J.; McBride, J. 2003. **A unique technique for street tree planting in Beijing.** Arboriculture Journal. 27: 1–10.

## Appendix 1: Site Type and Land Use Examples

Site type and land use Figure 8 photo series illustrates examples of how to classify urban trees for site type and land use with the protocols. Please see Field Guide section 2.6 Site Type and section 2.7 Land Use for more information and examples of the categories. The site type and land use categories are listed below for convenience.

### Site type categories

- Sidewalk cutout
- Sidewalk planting strip
- Median
- Planter box
- Other hardscape
- Front yard
- Side yard
- Back yard
- Maintained park
- Other maintained landscaped area
- Natural area

### Land use categories

- Single-family residential
  - Attached
  - Detached
- Multi-family residential
- Mixed use
- Commercial
- Industrial
- Institutional
- Maintained park
- Natural area
- Cemetery
- Golf course
- Agricultural
- Utility
- Water/wetland
- Transportation
- Vacant lot
- Other



**Figure 8.**—(A) Site type: sidewalk cutout; Land use: commercial. Photo by B.C. Sharenbroch, used with permission. (B) Site type: sidewalk planting strip; Land use: single-family residential—attached. Photo by L.B. Shafer, used with permission. (C) Site type: other hardscape; Land use: institutional. Photo by L.A. Roman, USDA Forest Service. (D) Site type: sidewalk cutout; Land use: institutional. Photo by B.C. Sharenbroch, used with permission. (E) Site type: sidewalk cutout; Land use: single-family residential—attached. Photo by B.C. Sharenbroch, used with permission. (F) Site type: other hardscape; Land use: commercial. Photo by L.A. Roman, USDA Forest Service.

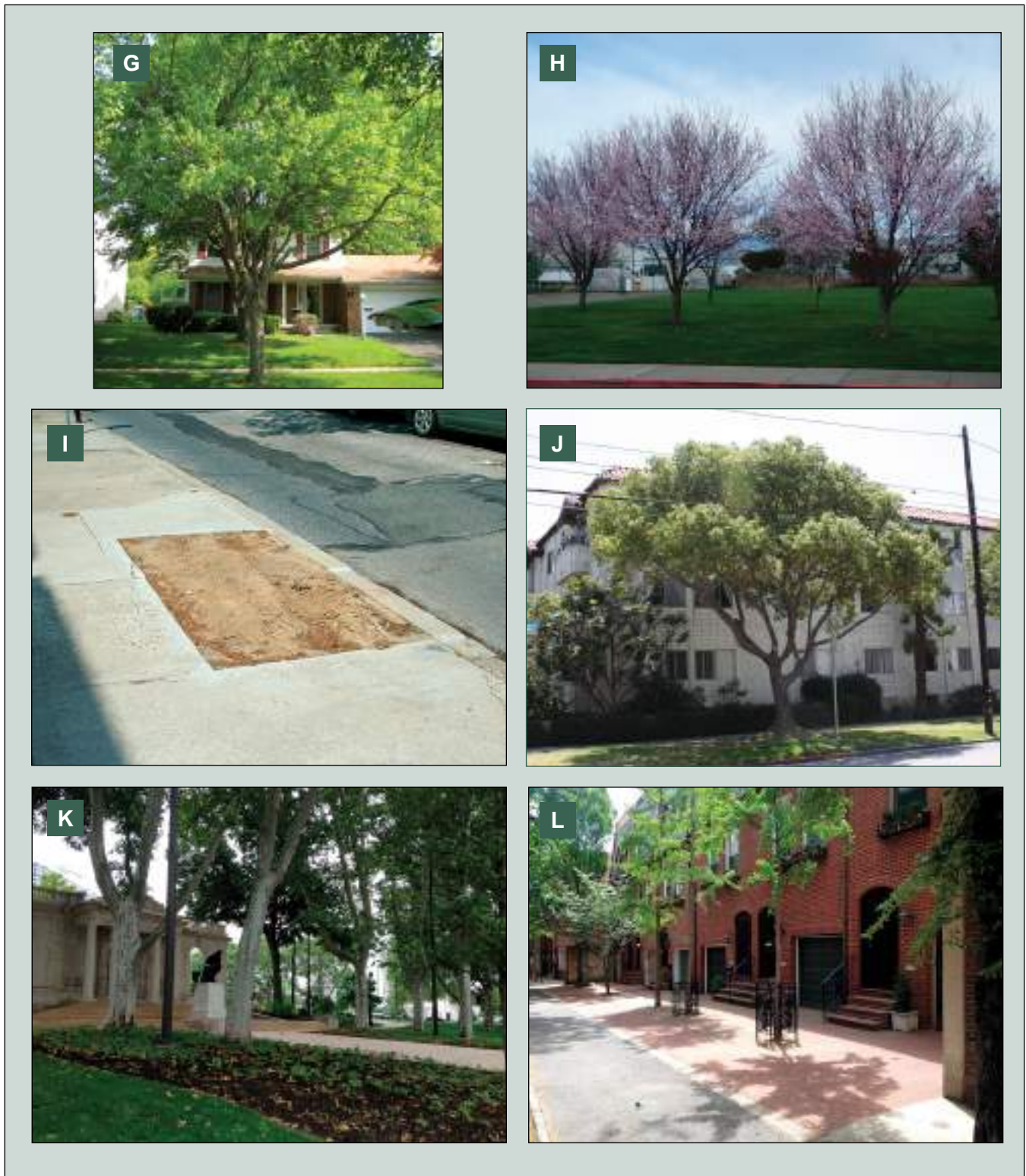

**Figure 8 (continued).**—(G) Site type: planting strip (foreground tree); Land use: single-family residential—detached. Photo by B.C. Sharenbroch, used with permission. (H) Site type: maintained park; Land use: maintained park. Photo by L.A. Roman, USDA Forest Service. (I) Site type: sidewalk cutout; Land use: vacant lot. Photo by J.P. Fristensky, used with permission. (J) Site type: planting strip; Land use: multi-family residential. Photo by N.S. van Doorn, USDA Forest Service. (K) Site type: maintained park; Land use: institutional. Photo by L.A. Roman, USDA Forest Service. (L) Site type: other hardscape, trees in a courtyard behind row homes; Land use: single-family residential—attached. Photo by J.P. Fristensky, used with permission.

## Appendix 2: Species Identification Resources

Below is a small sampling of available resources to assist with tree genus and species identification for urban trees in the United States and Canada. No single species identification resource covers all urban trees in this broad geographic area, and the resources listed below differ in their accessibility to field crews with different levels of botanical knowledge. Project supervisors may wish to create species identification guides specific to their cities, drawing on the information presented in these resources.

### Web Sites and Apps

#### **Arbor Day Foundation's What Tree Is That?**

[www.arborday.org/trees/whattree/mobile.cfm](http://www.arborday.org/trees/whattree/mobile.cfm)

A free step-by-step app that guides the user through tree species and genus identification using dichotomous key characteristics

#### **Audubon Field Guide to North American Trees**

<http://www.audubonguides.com/index.html>

A low-cost app with images and search function by leaf shape, region, bark, and other advanced options to assist in North American tree species and genus identification

#### **Leafsnap**

[www.leafsnap.com](http://www.leafsnap.com)

A free electronic app whereby users can input leaf photographs and see a list of potential tree species, from Columbia University, University of Maryland, and The Smithsonian Institution (Kumar et al. 2012)

#### **Virginia Tech Dendrology Fact Sheets**

<http://dendro.cnre.vt.edu/dendrology/factsheets.cfm>

Fact sheets from Virginia Tech describing trees common in North America, includes a slideshow about basic tree identification tips and photos for many species featuring leaves, reproductive parts, and bark

## Books

### **Audubon Society Field Guide to North American Trees: Eastern Region**

Field guide referencing nearly 700 species of trees found east of the Rocky Mountains, focusing mostly on natives but includes some exotic ornamental trees (Little 1980a)

### **Audubon Society Field Guide to North American Trees: Western Region**

Field guide referencing nearly 700 species of trees found west of the Rocky Mountains, focusing mostly on natives but includes some exotic ornamental trees (Little 1980b)

### **A Californian's Guide to the Trees Among Us**

Reference guide to over 150 of the most common urban trees in California (Ritter 2011)

### **City of Trees: The Complete Field Guide to the Trees of Washington, D.C.**

Guided tour of Washington D.C.'s trees and botanical keys to assist with species identification (Choukas-Bradley 2008)

### **Field Guide to the Street Trees of New York City**

Drawings and photographs accompany descriptions of 50 species commonly found in New York City (Day and Smoke 2011)

### **New York City Trees**

Park Department's field guide to more than 125 metro-area species of New York City and the metro region (Barnard 2002)

### **Philadelphia Trees: A Field Guide to the City and the Surrounding Delaware Valley**

Field guide to 118 species commonly encountered in and around Philadelphia, Pennsylvania (Barnard et al. 2017)

### **Sticky Trees—Learn to recognize at a glance the 15 most common trees in the United States – in just one hour, guaranteed**

Reference guide with images of 15 common trees within United States to assist in species identification (Holt 2010)

### **The Easy Tree Guide: Common Native and Cultivated Trees of the United States and Canada**

Portable guide useful for species identification in the field (Rushforth and Tomblin 2004)

**The Urban Tree Book: an Uncommon Field Guide  
for City and Town**

Identification guide for more than 200 species across North America.  
Includes illustrations and stories (Plotnik 2000)

**Trees of the California Landscape:  
a Photographic Manual of Native and Ornamental Trees**

Illustrated guide to California's trees including 107 native and 311  
ornamental species (Hatch and Faber 2007)

**Trees of Vancouver**

Reference guide to over 470 kinds of trees native to Canada and cultivated  
trees (Straley 1992)

**Vancouver Tree Book: a Living City Field Guide**

Pocket field guide profiling more than 110 of Vancouver's important species  
(Tracey 2016)

## Appendix 3: Other Protocols

*Urban Tree Monitoring: A Field Guide* (Roman et al. 2020) and *Urban Tree Monitoring: A Resource Guide* build on past work from a variety of researchers and professionals. The resources below offer related protocols for urban tree inventories and monitoring.

### **i-Tree Eco**

**Methods citations:** Nowak et al. 2008, i-Tree 2017a

**Overview:** For those interested in monitoring change across the entire urban forest—to represent citywide characteristics—random plots using the i-Tree Eco method may be most appropriate. This well-established protocol produces a summary of urban forest structure, functions, and services based on a single one-time inventory, but it can also be used for ongoing monitoring as long as plots are permanently referenced (see section 2.6). Compared to the Minimum Data Set, a larger set of variables about tree size, crown, and site conditions are included. Examples of monitoring studies using this approach to quantify urban tree mortality, growth, population change, and impacts of storms include Nowak et al. (2004), Staudhammer et al. (2011), Lawrence et al. (2012), and Lima et al. (2013).

### **Urban Forest Inventory and Analysis**

**Methods citations:** USDA FS (2017)

**Overview:** The USDA Forest Service’s Forest Inventory and Analysis (FIA) program is a long-term permanent plot network encompassing all of the nation’s closed-canopy forest. The goal of the FIA program is to create an accurate and timely inventory of the nation’s forests, to monitor current forest conditions, and to facilitate sustainable management. Recently, the FIA program has added methods for assessing urban forests that incorporate the statistical and scientific rigor of traditional FIA plots with methodology appropriate for urban settings. When fully implemented, Urban FIA (UFIA) will provide a nationwide network of urban forest monitoring plots spanning a diverse array of cities and land uses. Compared to the Minimum Data Set, a larger set of variables about tree size, crown, and site conditions are included. FIA and UFIA are conducted with professional field crews who must pass special certifications in these methods.

### **Planted Tree Re-Inventory Protocol**

**Methods citations:** Vogt and Fischer (2014)

**Overview:** This field protocol was developed by the Bloomington Urban Forest Research Group at the Center for the Study of Institutions, Populations and Environmental Change. The methods are specifically designed for neighborhood-based street tree planting projects, and include data on the planting site, tree growth, and observed maintenance. Examples of monitoring studies using this method include Vogt et al. (2015a) and Widney et al. (2016).

### **TreeKIT Collaborative Mapping Method**

**Methods citations:** Silva et al. (2013)

**Overview:** This field protocol was developed to enable community volunteers to measure and map street trees in New York City, New York. The block edge distance method for recording street tree location (see Field Guide section 2.4.2) is based on these protocols. That location method was also used for TreesCount! 2015, a citizen science street tree inventory project in New York City.

### **Standard for Tree Inventory in Urban Environments—Sweden**

**Methods citations:** Östberg et al. (2012, 2013)

**Overview:** Urban forestry researchers in Sweden realized that the different municipalities there had widely varying tree inventory methods. Municipalities were surveyed to understand the different parameters that each used, and a common core of parameters was used by most cities. The standard inventory has been well-received by the urban forestry industry in Sweden. Benefits of the national urban tree inventory standards include making national recommendations on how to create a tree management plan as well as how to work with hazard trees and helping the industry to get more coherent language and terminology.

## Appendix 4: Field Crew Training Agendas and Activities

Below are examples of field crew training agendas for the Minimum Data Set as well as activities that could be used during training.

### Agenda No. 1: Full-Day (7 Hours) Field Crew Training Agenda for Interns or Citizen Scientists

This is the training schedule that was used for citizen scientist training for the pilot test of the Field Guide (Roman et al. 2017) as well as seasonal interns. This training agenda could also be adapted to take place over two evening sessions to enable volunteers to participate after the work day. If more time can be used to train interns or volunteers, the training could be lengthened to 2 days to allow for longer lessons (e.g., more time with species identification) as well as a full day of field practice.

9:00-9:30	Introductions, overview of project, goals of the monitoring, phone contacts
9:30-10:00	Field crew information, date, site type, land use, location
10:00-11:30	Species including identification practice
11:30-12:15	Lunch
12:15-1:00	Mortality status, basal sprouts, crown vigor
1:00-2:00	Trunk diameter
2:00-3:30	Outdoor practice <ul style="list-style-type: none"> <li>• Reinforce how to use standard equipment, species identification</li> <li>• Have several crews record the same trees independently and compare their observations</li> </ul>
3:30-3:45	Discussion about field measurements, sources of error activity
3:30-4:00	Safety training and pedestrian interactions

## Agenda No. 2: Short (2.5 hours) Training Agenda for Interns or Citizen Scientists

Note that this training is for planted tree cohort monitoring and assumes that in-depth species identification skills are not needed because species information is available from planting records.

9:00-9:20	Introductions, overview of project, goals of the monitoring, phone contacts
9:20-9:40	Location and species confirmation
9:40-10:00	Crown vigor
10:00-10:20	Trunk diameter
10:20-10:40	Discussion, sources of error activity, team assignments
10:40-11:30	Outdoor practice

### Activity No. 1: D-tapes and Wrists

**Materials:** d-tape, paper, pens, tape measurers two to three urban tree examples

**Objective:** To learn how to use a d-tape and to understand causes of variation in measurements

**Time required:** 5 to 8 minutes

Have the trainees pair up. Each trainee should record diameter of partner's wrist. Change partners and repeat, keeping track of whose wrist corresponds with each measurement.

Meanwhile, the supervisor or trainer walks around and checks to make sure that best practices are being followed (e.g., d-tapes are not being read backwards, d-tapes are wrapped snug).

After a few measurements are recorded, reorganize into a group again. Explain that the wrist is not a perfect circle, as many trees will not be and that variations in where the d-tape is placed on the wrist will make a difference in the data. Discuss lessons learned.

### Activity No. 2: Sources of Error

**Materials:** Post-its®, pens

**Objective:** Field crew will be able to identify examples of measurement error (informally termed "human error" for the purpose of this exercise) and natural variability in tree dimensions (informally termed "tree error"). Field crew will brainstorm ways to correct for measurement error.

**Time required:** 10 to 15 minutes

This activity should happen at the end of a training session, after the supervisor has explained the objectives for the urban tree monitoring project and protocols for recording each variable.

Each trainee gets a small stack of post-its. Trainees write down as many sources of error or discrepancies they can imagine while collecting data.

Use post-its to create two categories: “tree and site issues” (i.e., something is particularly challenging about certain trees or sites) and “human issues” (i.e., a person made a mistake). Have crew members individually sort their post-its into these two categories.

Review and discuss. Brainstorm solutions to deal with each “tree and site issues.” Brainstorm solutions to deal with each “human issues.”

**Activity No. 3: Address and Site Code Map Quiz**

**Materials:** Pens, printed site code table and diagram (below).

**Objective:** To understand the address and site code location method.

Have trainees practice recording the information in Table 21 using the map in Figure 9A. This is the same example used in the Field Guide (Table 4, Figure 2A), so have trainees close their Field Guides while they do this activity. Upon completion of the exercise, trainees may use the answer key in Figure 9B to check their work.

**Table 21.—A datasheet used for practicing the address and site code method**

Tree number	Site code	Address # and street name	Block Information			
			On street	From street	To street	Side of street
11	1F	200 Apple St.	Apple St.	Maple St.	Juniper St.	W
2	1F	202 Apple St.	Apple St.	Maple St.	Juniper St.	W
15	1A	204 Apple St.	Apple St.	Maple St.	Juniper St.	W
12	2A	204 Apple St.	Apple St.	Maple St.	Juniper St.	W
5	3A	204 Apple St.	Apple St.	Maple St.	Juniper St.	W
6	1F	201 Apple St.	Apple St.	Maple St.	Juniper St.	E
7	2F	201 Apple St.	Apple St.	Maple St.	Juniper St.	E
30	1F	205 Apple St.	Apple St.	Maple St.	Juniper St.	E
9	1R	208 Pear St.	Apple St.	Maple St.	Juniper St.	E
10	2R	208 Pear St.	Apple St.	Maple St.	Juniper St.	E
46	2S	208 Pear St.	Juniper St.	Pear St.	Apple St.	S
4	1S	208 Pear St.	Juniper St.	Pear St.	Apple St.	S
13						
14						
26						
16						
17						
18						
88						
20						
1						
22						
23						
24						
25						
49						
27						
28						
29						
3						

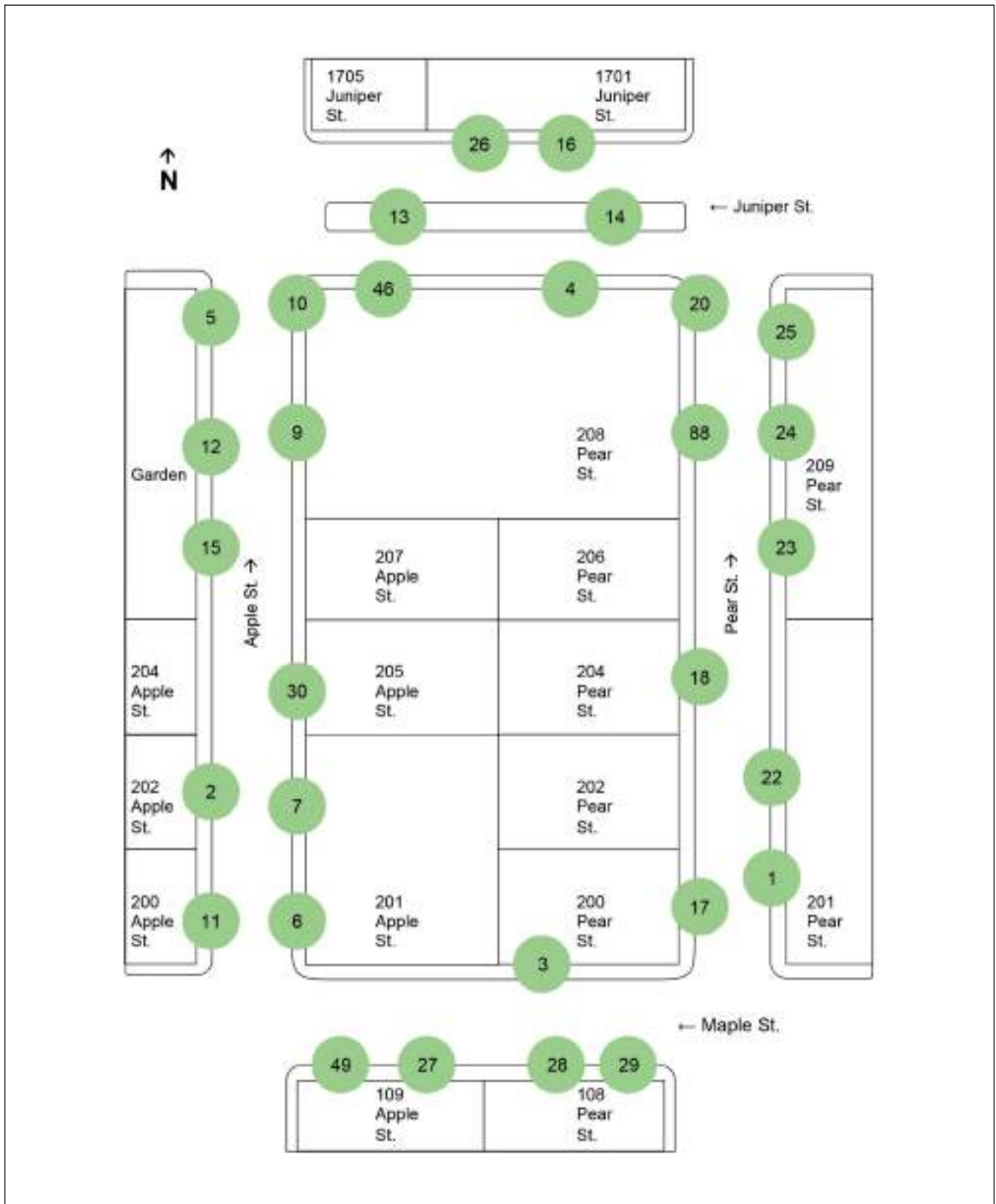
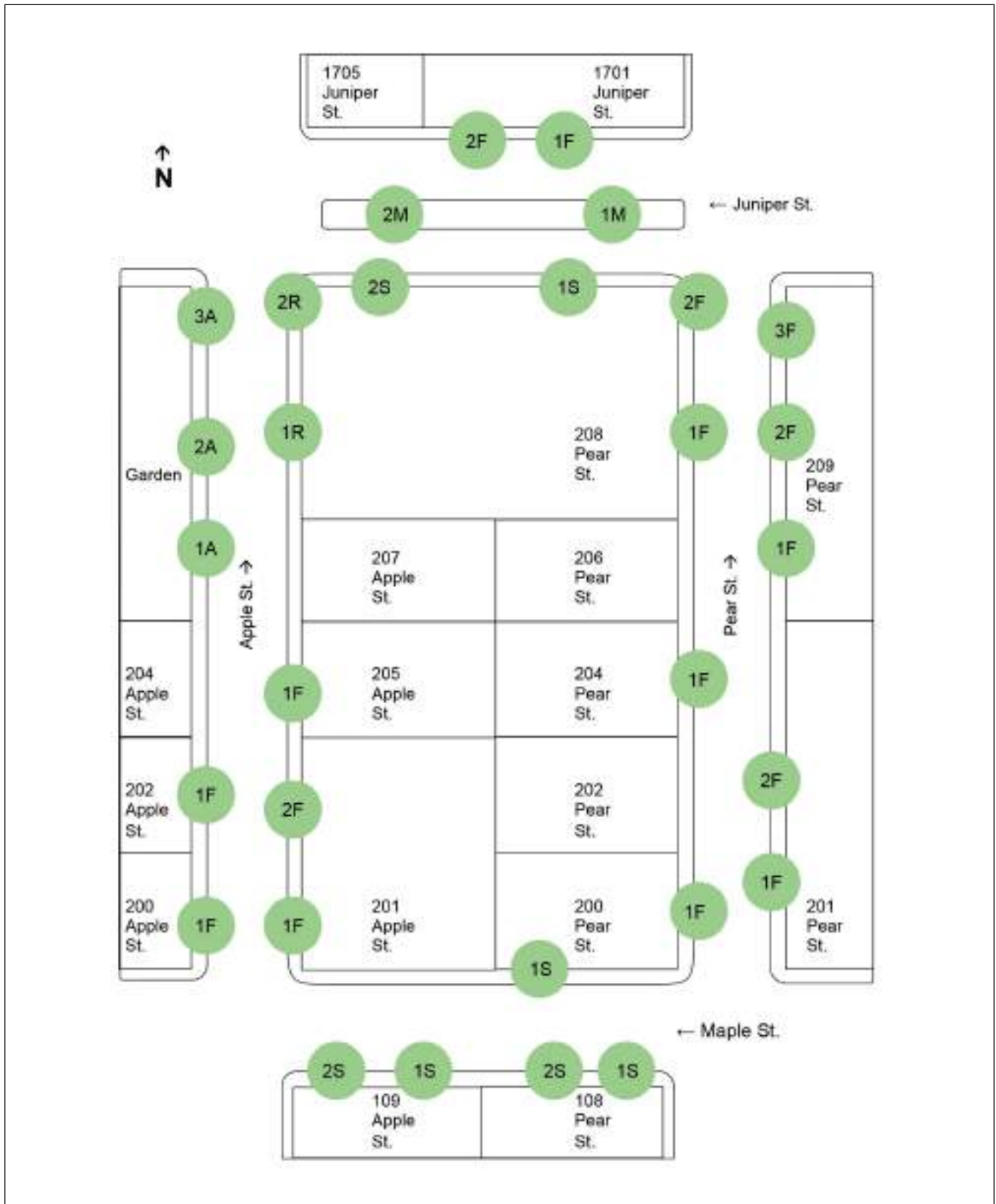

Figure 9A.—A map used for practicing site code identification.



**Figure 9B.**—Address and site code map of an imaginary block which corresponds to Table 21. Arrows with the street names indicate ascending order of address numbers on that street. Whereas Figure 9A has tree numbers to designate each tree, this figure shows the site codes for each tree.

## Glossary

**allometry**—The sizing relationships of trees (e.g., equations to estimate height, crown dimensions, and biomass from trunk size).

**annual mortality rate**—The proportion of individual trees dying (or getting removed) over a year (Roman et al. 2016).

**annual survival rate**—The proportion of individuals surviving over a year (Roman et al. 2016).

**basal sprouts**—Sprouts that grow from buds at the base of the stem or in the roots of a tree; are also sometimes called suckers or water sprouts.

**baseline records**—The first set of tree data relevant to the monitoring project; these records are the starting point from which comparisons will be made going forward.

**caliper tool**—A measurement instrument used to measure the distance between two sides of an object; in urban forestry, caliper tools may be used to measure small trees or trunks that have obstructions.

**citizen science**—An approach to engaging the public in ecological research and natural resource management (Dickinson et al. 2010, 2012; Tulloch et al. 2013), and a citizen scientist is generally considered “a volunteer who collects or processes data as part of a scientific enquiry” (Silvertown 2009).

**crowdsourcing**—An approach to data collection in which a large number of volunteers submit data when and where they wish; crowdsourcing is a citizen science approach that can be used for ecological field data.

**diameter at breast height (d.b.h.)**—Diameter of a tree’s trunk at breast height (standard height in the United States is 4.5 ft or 1.37 m from the ground).

**diameter at caliper height (d.c.h.)**—Diameter of a tree’s trunk at 1 ft (30.5 cm) from the ground.

**d-tape**—Also known as diameter tape, this is specialized forester’s measuring tape that is the best piece of equipment for measuring a trunk diameter that is  $\geq 1$  in (2.5 cm).

**establishment phase**—The first few years after planting (Hilbert et al. 2019), although establishment of planted urban trees has been variously defined (Leers and Moore 2018, Levinsson et al. 2017).

**fine twig dieback**—Recent mortality in the upper and outer portion of the crown, and reflects the severity of recent stresses on a tree (USDA FS 2016).

**foreign key**—In a relational database, the foreign key is a field or collection of fields that references the primary key or unique key of another table, thereby establishing a link between them.

**forest land**—A definition of forest used in the FIA program, areas at least 1 ac (0.4 ha), 120 ft (36.6 m) wide, 10 percent stocked with trees, and with undisturbed understories (Cumming et al. 2007, 2008; Oswalt et al. 2014).

**i-Tree**—A free software suite for urban forest inventories, tree cover evaluations, and ecosystem services estimation from the USDA Forest Service and Davey Tree Expert Co.

**i-Tree Eco**—The flagship software in the i-Tree suite, applicable to plot-based samples and complete censuses across any population of interest where ecosystem services estimation and valuation are of interest, formerly known as UFORE.

**i-Tree Streets**—A component of the i-Tree suite, for street tree inventories and ecosystem services estimation, formerly known as STRATUM.

**ingrowth**—For a multi-age inventory remeasurement, ingrowth reflects new trees in the system owing to planting or natural regeneration.

**land use**—Description of the way the property around (or adjacent to) the tree is used by humans, see also Anderson et al. (1976), Lambin et al. (2006), and The Institute for Local Government (2010) for more about land use definitions.

**long-term field monitoring**—“Repeated field-based empirical measurements” (Lindenmayer and Likens 2010a), and in the ecological context, long-term is taken to mean at time scales of a decade or more (Lindenmayer and Likens 2010b), although shorter monitoring time scales can be highly relevant in urban forests (e.g., mortality, growth, and health of trees one year after planting).

**longitudinal data**—Repeated observations on the same individual trees over time.

**long format data**—Also known as stacked data; a format in which there is at least one column listing categories (e.g., Treeid) and one column listing values associated with each of those categories (e.g., d.b.h. centimeters); categories are repeated for as many observations as were recorded.

**metadata**—A set of data that describes other data, and specifically a metadata repository (also known as a data dictionary) generally stores information about the fields in a database, such as definitions of each field and allowable values.

**monitoring**—Systematic assessment or tracking over a period of time; this Urban Tree Monitoring resource guide is concerned with field-based monitoring of urban trees, and other forms of urban forest monitoring are discussed in Leff (2016).

**mortality**—For urban trees, mortality is generally defined as a combination of trees that died in place and trees removed.

**multi-age inventory monitoring**—Monitoring trees within a given geographic area (e.g., plots, neighborhoods), regardless of who planted or when, such as repeated street tree inventories or plot-based inventories.

**planting cohort**—Refers to the collection of trees planted around the same time (e.g., same planting season or same calendar year).

**planting cohort monitoring**—Approach that refers to tracking trees planted or distributed through a specific program and planted around the same time.

**population growth rate**—The rate of increase or decrease in total population size.

**primary key**—In a relational database, the primary key uniquely identifies every record.

**quality control**—A system of maintaining a standard of data quality by testing a sample of the data collected against the specifications.

**replacement tree**—Tree planted in the exact same location as removed tree, often most relevant for street tree sidewalk cut-outs.

**right-of-way**—A strip of land occupied by certain public or transportation uses (The Institute for Local Government 2010); often refers in the urban forestry context to the public right-of-way along roads which encompasses street trees, but may also refer to right-of-way areas along railroad or utility corridors.

**site type**—Description of the tree's immediate location or planting site.

**stocking**—The amount of trees in a particular area, generally given in relation to optimum levels (Powell 1999, Richards 1992).

**survivorship**—The proportion of a planting cohort surviving to a particular time (i.e., cumulative survival, Roman et al. 2016).

**tree demography**—The study of population dynamics of trees, including analysis of change over time in mortality and growth.

**tree growth**—Growth in tree size, can include d.b.h. (also known as radial growth of the main stem), height, and canopy width growth; often expressed as an annual rate of growth.

**unique key**—In a relational database, a unique key is what defines uniqueness for the entity that is being stored on the record.

**urban forest**—While various definitions of the term urban forest exist (Konijnendijk et al. 2006, Piana and Troxel 2014), a common definition used in the United States is “all publicly and privately owned trees within an urban area—including individual trees along streets and in backyards, as well as stands of remnant forest” (Nowak et al. 2010).

**Urban Forest Inventory and Analysis (UFIA)**—the urban expansion of the USDA Forest Service’s congressionally mandated ongoing forest inventory and monitoring across the United States through a national plot system.

**wide format data**—Also known as unstacked data; a format in which each category of variables is represented by a single row (e.g., all observations for a tree are in one row); each different data variable (e.g., d.b.h.cm.2010, d.b.h.cm.2015) is in a separate column so observations across time span multiple columns.





van Doorn, Natalie S.; Roman, Lara A.; McPherson, E. Gregory; Scharenbroch, Bryant C.; Henning, Jason G.; Östberg, Johan P.A.; Mueller, Lee S.; Koeser, Andrew K.; Mills, John R.; Hallet, Richard A.; Sanders, John E.; Battles, John J.; Boyer, Debra J.; Fristensky, Jason P.; Mincey, Sarah K.; Peper, Paula J.; Vogt, Jessica M. 2020. **Urban tree monitoring: a resource guide**. Gen. Tech. Rep. PSW-GTR-266. Albany, CA: U.S. Department of Agriculture, Forest Service, Pacific Southwest Research Station. 132 p.  
<https://doi.org/10.2737/PSW-GTR-266>.

The guidelines proposed in *Urban Tree Monitoring: A Resource Guide* (hereafter referred to as the Resource Guide) were developed and refined over many years to address the need for standardized urban tree monitoring protocols. The Resource Guide provides in-depth guidance for urban forest managers and researchers who want to design and implement a tree monitoring project. This Resource Guide is a companion to *Urban Tree Monitoring: A Field Guide*; however, the Resource Guide can also be used on its own. The Resource Guide is divided into three parts. In Part I, we discuss (1) the varied goals of monitoring projects and how to match data collection to those goals, (2) the development of these urban tree monitoring standards, (3) types of monitoring projects, and (4) connections to other protocols for urban tree data collection. We offer guidance on methods for recording tree location, developing tree record identifiers, organizing spreadsheets and databases, choosing data collection systems, fostering research-practice partnerships, training crews, and managing fieldwork. In Part II, we present five monitoring data sets: Minimum Data Set, Tree Data Set, Site Data Set, Young Tree Management Data Set, and Community Data Set. We list study goals that could be addressed with each data set and descriptions of relevant variables. We also provide guidance regarding which variables are best suited for beginner and advanced crews. Lastly, in Part III we include appendices with additional resources for designing and implementing tree monitoring projects.

KEY WORDS: Urban forest, tree monitoring, citizen science, tree survival, tree demography, longitudinal data.

---

---

In accordance with Federal civil rights law and U.S. Department of Agriculture (USDA) civil rights regulations and policies, the USDA, its Agencies, offices, and employees, and institutions participating in or administering USDA programs are prohibited from discriminating based on race, color, national origin, religion, sex, gender identity (including gender expression), sexual orientation, disability, age, marital status, family/parental status, income derived from a public assistance program, political beliefs, or reprisal or retaliation for prior civil rights activity, in any program or activity conducted or funded by USDA (not all bases apply to all programs). Remedies and complaint filing deadlines vary by program or incident.

Persons with disabilities who require alternative means of communication for program information (e.g., Braille, large print, audiotope, American Sign Language, etc.) should contact the responsible Agency or USDA's TARGET Center at (202) 720-2600 (voice and TTY) or contact USDA through the Federal Relay Service at (800) 877-8339. Additionally, program information may be made available in languages other than English.

To file a program discrimination complaint, complete the USDA Program Discrimination Complaint Form, AD-3027, found online at [http://www.ascr.usda.gov/complaint\\_filing\\_cust.html](http://www.ascr.usda.gov/complaint_filing_cust.html) and at any USDA office or write a letter addressed to USDA and provide in the letter all of the information requested in the form. To request a copy of the complaint form, call (866) 632-9992. Submit your completed form or letter to USDA by: (1) mail: U.S. Department of Agriculture, Office of the Assistant Secretary for Civil Rights, 1400 Independence Avenue, SW, Washington, D.C. 20250-9410; (2) fax: (202) 690-7442; or (3) email: [program.intake@usda.gov](mailto:program.intake@usda.gov).

---

---



Printed on recycled paper